

CONTENT

Chapter1Overview -----	2
1.1 Safety requirement and cautions.....	2
1.2 Before Use.....	3
1.3 Specification parameters.....	3
1.4 Technical specifications.....	4
Chapter 2 Installation -----	6
2.1 Control terminal.....	6
2.2 Description of connection function of conversion terminal.....	7
2.3 Wiring mode of Electrical circuit.....	8
2.4 Product dimensions.....	10
2.5Keyboard size.....	11
Chapter 3 Keyboard Layout and Operation Instructions -----	12
3.1 Keyboard appearance.....	12
3.2 Key function.....	12
3.3 Indicator light description.....	12
Chapter 4 Function Parameter Table -----	13
4.1 Description of the meanings in the function code parameter brief table.....	13
4.2Basic parameters.....	13
4.3 Terminal input function selection.....	35
4.4 Terminal output function selection.....	35
4.5 Monitoring code.....	36
4.6 Fault code table.....	37
Chapter 5 Regular Inspection and Maintenance -----	41
5.1 Inspection.....	41
5.2 Product storage.....	42
Chapter 6 Operation Guidance -----	43
Appendix 1: Modbus Communication Protocol -----	46
Appendix 2: Terminal connection mode -----	48
Appendix 3: Terminal connection mode -----	48

Chapter 1 Overview

This chapter provides an overview of the contents, purpose, compatibility, and the intended audience of this manual.

The XX series solar pump inverters is a low voltage pumps inverter of 0.3 to 400KW above rating designed to operate with energy drawn from solar panel or photovoltaic cells (PV).

The inverters is customized to operate in dual supply mode (Ac and DC), so the grid connected supply is used in the absence of energy from PV cells. This drive functions with the latest in technology maximum power point tracking (MPPT) algorithm to derive maximum power from the PV cells at any instant.

This supplement manual intends to serve as a quick start guide for installing, commissioning and operating the XX solar pump inverter.



This manual includes all the required parameters settings and program features specific to the solar pump

1.1 Safety requirement and cautions

Please do totally understand this part before using the inverter.

Warning signs and meanings

This manual has used following signs which means there is an important part of security. While observing against the rules, there is a danger of injury even death or machine system damage.

 DANGER	Danger: Wrong operation may cause death or large accident.
 CAUTION	Caution: Wrong operation may cause minor wound.

Operation requirement

Only professionally trained persons can be allowed to operate the equipment. "Professional trained persons" means the workers must have experience professional trained skill, and must be familiar with installation, wiring, running and maintain and can rightly deal with emergency cases in use.

Safety guidance

Warning signs come for your security. They are measures to prevent the operator and machine system from damage. Please carefully read this manual before using and strictly observe the regulations and warning signs while operating.

- Correct transportation, store, installation, careful operation and maintenance are important for inverter safe operation. In transport and store process, make sure the inverter is free from impact and vibration. It must be stored where is dry without corrosive air and conductive dust, and the temperature must be lower than 60°C;
- This product carries dangerous voltage and controls driver machine with potential danger. If you don't abide by the regulations or requirements in this manual, there is danger of body injury even death and machine system damage;
- Do not wire while the power is connected. Otherwise, there is danger of death for electric shock. Before wiring, inspection and maintenance, please cut off power supply of all related equipment's and ensure main DC voltage in safe range. And please operate it after 5 mins;
- Power wire, motor wire and control wire should be all connected firmly. Earth must be reliable and earth resistance must be lower than 10Ω;
- Human body electrostatic will damage inner sensitive components seriously. Before operation, please follow ESD measures. Otherwise, there is danger of inverter damage;
- Inverter output voltage is pulse wave. If components such as capacitor which improves power factor and pressure-sensitive resistance for anti-thunder and so on are installed at the output side, please dismantle them or change to input side;
- No switch components such as breaker and contactor at the output side (if there must be one, please make sure the output current is 0 while the switch acting);
- No matter where the fault is, there is danger of serious accident. So there must be additional external prevent

measures or other safety devices;

- Only used in application fields as maker stated. No use in equipments related to special fields such as emergency, succor, ship, medical treatment, aviation, nuclear and etc;
- Only authorized service center can maintain the products. It may cause product fault while using accessories not authorized or permitted. Any defective components must be changed in time in maintenance.

1.2 Before Use

On receiving your order, please check the package and confirm intact before opening, and check if there's any damage, scratch or dirt (damages caused during transportation are not within the company's warranty). If there's any damage caused during transportation, please contact us or the transport company immediately. After confirming the receipt of the goods intact, please re-confirm if the product and your order are consistent.

1.3 Specification parameters

1.3.1 Nameplate model description and rated parameters

XX-D3-22G-B

1
2
3
4
5
6

Field	Identification	Label description
Inverter type	1	XXM series Solar photovoltaic water pump inverter
Voltage classification	2 3	D1/S1 means, input voltage 90-400VDC, inverter output 0-110VAC D2/S2 means input voltage 150-450VDC inverter output 0-220VAC D3/T3 means input voltage 250-800VDC inverter output 0-380VAC
Adaptive motor power	4	0R75: 0.75KW, 1R5: 1.5KW, 2R2:2.2KW, 004: 4KW
Inverter type	5	G: Type G (heavy duty) , 150% rated current for 60 minute for overload capacity F: Type inverter (pump and fans dut) 120% rated current for 60 minutes for over load capacity

1.3.2 Specification and rated parameters

D1: General type:90V DC to 400V DC or 110V±15% AC, 50/60Hz		D2: General type:150V DC to 450V DC or 220V±15% AC, 50/60Hz	
Inverter specification	Current (A)	Inverter specification	Current (A)
XX-D1-R75G-B	7	XX-D2-R75G-B	4
XX-D1-1R5G-B	10	XX-D2-1R5G-B	7
		XX-D2-2R2G-B	10
		XX-D2-004G-B	16

D3: General type:250V DC to 750V DC or 380V±15% AC, 50/60Hz		T3: General type:350V DC to 750V DC or 380V±15% AC, 50/60Hz	
Inverter specification	Current (A)	Inverter specification	Current (A)
XX-D3-R75G-B	3	XX-D3-037G	75
XX-D3-1R5G-B	4	XX-D3-045G	90
XX-D3-2R2G-B	6	XX-D3-055G	110
XX-D3-004G-B	10	XX-D3-075G	150
XX-D3-5R5G-B	13	XX-D3-090G	180
XX-D3-7R5G-B	17	XX-D3-110G	210
XX-D3-011G-B	25	XX-D3-132G	250
XX-D3-015G-B	32	XX-D3-160G	310
XX-D3-018G-B	38	XX-D3-185G	360
XX-D3-022G-B	45	XX-D3-200G	400
XX-D3-030G	60	XX-D3-220G	410

1.4 Technical specifications

Item		Specification
Power input	Voltage, frequency	D1/S1: 90V DC to 400V DC or 110V ± 15% AC, 50/60Hz D2/S2: 150V DC to 450V DC or 220V ± 15% AC, 50/60Hz D3/T3: 250V DC to 750V DC or 380V ± 15% AC, 50/60Hz D5/D5: 350V DC to 900V DC or 480V ± 15% AC, 50/60Hz
	Allowable fluctuations	voltage unbalance rate: <3%; Frequency: ±5%; aberration rate: as IEC61800-2
	Power factor	≥0.94(with DC reactor)
	Efficiency	≥96%
	MPPT efficiency	≥99.6%
Output	Output voltage	Output under rated condition: 3 phase, 0~input voltage, inaccuracy <5%
	Output frequency	G type: 0~600Hz
	Output frequency	Max frequency ±0.5%
	Overload capacity	G type: 150% rated current/1 min, 180% rated current/10s, 200% rated
Main control performance	Motor control mode	V/F without PG, VC without PG, VC with PG
	Speed control range	Vector control without PG, rated load 1:100; Vector control with PG, rated load 1:1000;
	Steady speed accuracy	VC without PG: ≤2% rated synchronized speed; VC with PG: ≤0.05% rated synchronized speed
	Starting torque	VC without PG: when 0.5Hz, 150% rated torque; VC with PG: when 0Hz, 200% rated torque
	Torque response	VC without PG: ≤20ms; VC with PG: ≤10ms.
	Frequency accuracy	Digit setting: max frequency × ±0.01%; Analog setting: max frequency × ±0.2%
	Frequency resolution	Digital setting: 0.01Hz; Analog setting: maximum frequency × 0.05%
	DC braking capacity	Starting frequency: 0.00~50.00Hz; Braking time: 0.0~60.0s; Braking current: 0.0~150.0% rated current

Item		Specification
	Torque boost capacity	Auto torque upgrade 0.0%~100.0%; Manual torque upgrade 0.0%~30.0%
	V/F curve	4 modes: one linearity torque characteristic curve ,one self-setting V/F curve mode, one drop torque characteristic curve (1.1- 2.0 powers),and square V/F curve mode.
	Acceleration/Deceleration curve	2 modes: linear Acceleration/Deceleration and S curve Acceleration/Deceleration. 4 sets of ACC/DEC, time unit 0.01s selectable, longest time: 650.00s.
	Rated output voltage	Rely on power supply voltage compensate function, while motor rated voltage is 100%, set it at the range of 50-100%(output can not over input voltage).
	Voltage auto-adjustment	While power supply voltage fluctuates, it can auto-keep constant output voltage.
	Auto energy-saving running	While under V/F control mode, according to load situation, auto-optimize output voltage to save energy.
	Standard functions	PID control, speed track, power off restart, jump frequency, upper/lower frequency limit control, program operation, multi- speed, RS485, analog output, frequency impulse output.
	Frequency setting channels	Keyboard digital setting, keyboard potentiometer ,Analog voltage/current terminal AI1、 AI2, Communication given and multi-channel terminal selection,Main and auxiliary channel combination, expansion card, supporting different modes switch.
	Feedback input channel	Voltage/Current Terminal AI1, Voltage/Current Terminal AI12, Communication given, pulse input X5.
	Running command channel	Operation panel given、 external terminal given, communication given, expansion card given.
	Input command signal	Start, stop, FWD/REV, JOG, multi-step speed, reset, ACC/DEC time selection, frequency given channel selection, exterior fault alarm.
Protective function		Overvoltage, under-voltage, current limit, over-current, overload, electric thermal relay, overheat, overvoltage stall, data protection, rapid speed protection, input/output phase failure protection.
Environment	Install place	altitude ≤ 1000m,above 1000m down the rated amount, each increase of 100m down the rated amount of 1%;no condensation, ice ,rain, snow, hail; solar radiation below 700W/m ² , air pressure 70-106 kPa.
	Temperature, humidity	-10 ~ + 50 ℃, derating above 40 ℃, maximum temperature 60 ℃ (no-load operation)5% to 95% RH (non-condensing)
	Vibration	When 9~200Hz, 5.9m/s ² (0.6g)
	Storage temperature	-30 ~+60℃
	Protection grade	IP20
	Cooling method	Forced air cooling

Chapter 2 Installation

In order to ensure the safe use of the product by the user, maximize the performance of the inverter, and ensure the reliable operation of the inverter, please use this product strictly in accordance with the environmental, wiring, and ventilation requirements described in this chapter



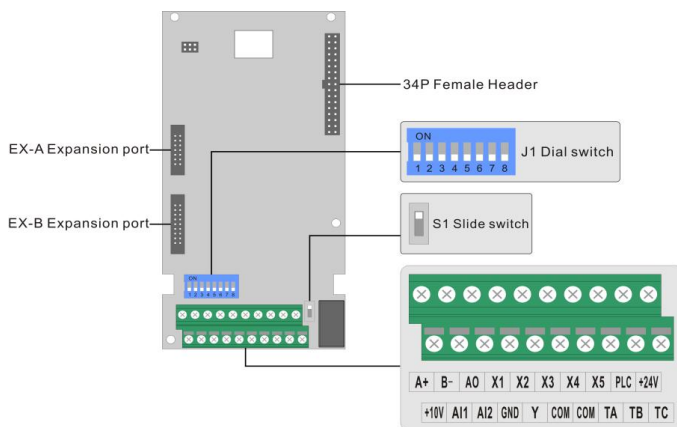







2.1 Control terminal

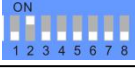
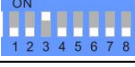
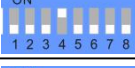
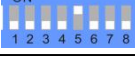

Type	Terminal	Terminal name	Terminal function definition
Power	+10V-GND	External + 10V power supply	10V auxiliary power supply output, constitutes loop with GND. Maximum output 10VDC / 50mA
	+24V-COM	External 24V power supply	Provide + 24 V power supply to the outside, and the maximum output is 100mA
Analog input	AI1-GND	Analog terminal 1	Input range: DC 0V-10V/4mA-20mA, It is determined by the AI-1 dial switch on the control board; Input impedance: 100k Ω for voltage input and 500 Ω for current input.
	AI2-GND	Analog terminal 2	Input range: DC 0V-10V/4mA-20mA, It is determined by the AI-2 dial switch on the control board; Input impedance: 100k Ω for voltage input and 500 Ω for current input.
Digital input	(X1-X4) -COM	Digital input 1-4	Internal photoelectric converter, programmable action, input conditions: maximum dc30v / 8mA
	X5-COM	High speed pulse terminal	With x1-x4 function and high-speed pulse input function, the maximum input frequency is 100kHz
Analog output	AO1-GND	Analog output1	The output voltage, current and frequency are selected by AO1 dial switch on the control board; Voltage type: 0-10V; current mode: 0-20mA / 4-20mA; frequency type (Collector open circuit): 0-50khz
Relay output	TB1-TC1	Normally closed	Can be programmed to set the action object, the maximum contact capacity: 3A/240VAC5A/30VDC
	TA1-TC1	Normally open terminal	
Y terminal	Y-COM	Digital output terminal	Open collector output, programmable action object, maximum output DC24V / 50mA

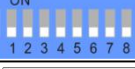
Type	Terminal	Terminal name	Terminal function definition
Communication	A+	Communication terminal A+	RS485 communication interface
	B-	Communication terminal B-	

2.2 Description of connection function of conversion terminal

Type	Switch position number	Terminal function	Choice position	Legend	Function description
Dial switch  Dial to the "on" side is valid, otherwise it is invalid.	1	GND-PE	PE		GND and PE are connected to the earth
	2	COM-PE	PE		COM and PE are connected to the earth
	3	AO1	AO1-U		(AO1)0~10V Voltage output
	4		AO1-I		(AO1)0~20mA/4~20mA Current output
	5		AO1-F		(AO1)FM Frequency output (open collector output) 0-50kHz
	6	485 communication matching resistance	Access		485 communication access 120 Ω matching resistance
	7	AI2	I		(AI2) 0~20mA/4~20mA Current input
			U		(AI2)0~10V Voltage input
	8	AI1	I		(AI1) 0~20mA/4~20mA Current input
			U		(AI1)0~10V Voltage input
	UP	PLC common terminal selection	+24V		PLC common terminal connected with + 24 V
	DOWN		COM		PLC common terminal connected with COM

2.3Wiring mode of Electrical circuit

2.3.1 The wiring mode of the control circuit of the frequency converter is shown in the figure on the following page:

Be careful:

- R, S and T terminals (R/L and T/N) used to connect AC grid power supply 3phase 220v or 3 phase 380VAC input. And P and P- used to connect DC power supply. P+ terminals must connect positive of DC solar power and P- (N) must connect negative of DC solar power supply. Otherwise it will cause inverter damaged seriously.
- The R and T terminals also can use to connect DC solar power supply and no need to distinguish negative and positive
- This inverter can compatible with connecting DC power supply input and AC grid power supply input at the same time. But please connect a backward diode between P and P- (N) and inverter which use to prevent current forward to solar panels and damaged solar panels.
- When connecting both AC grid and DC solar power together, the inverter drawing power as according to which side power voltage is higher.

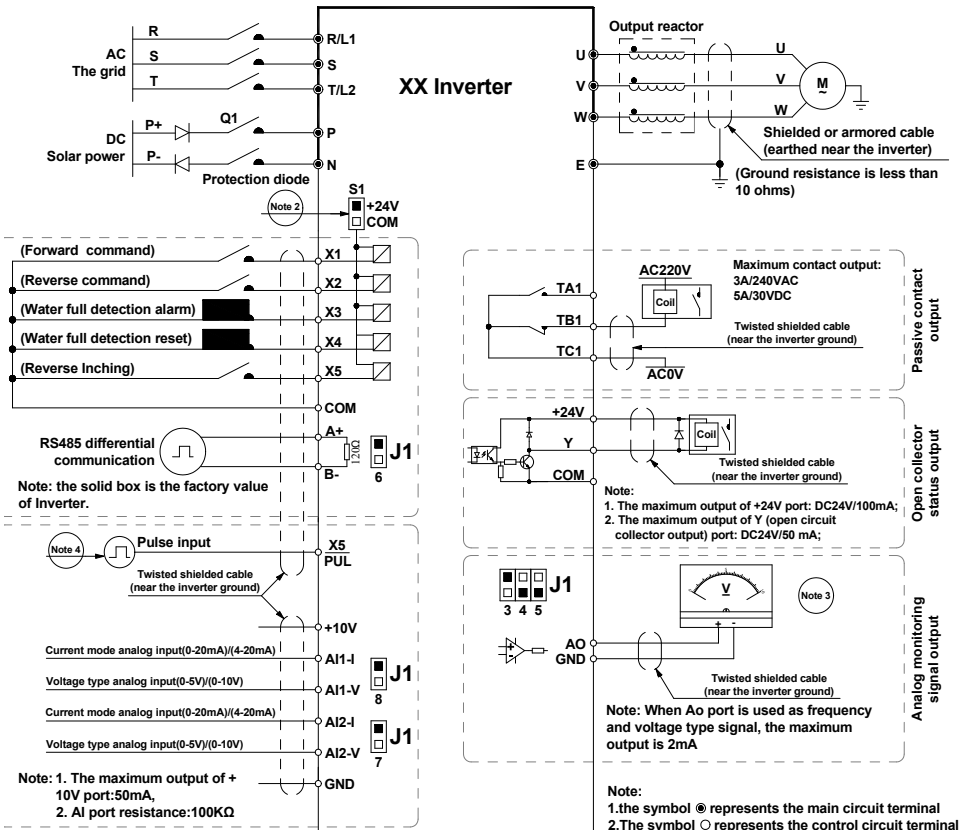

2.3.2 Multi function contact input connection

Connection mode of PNP characteristic transistor:

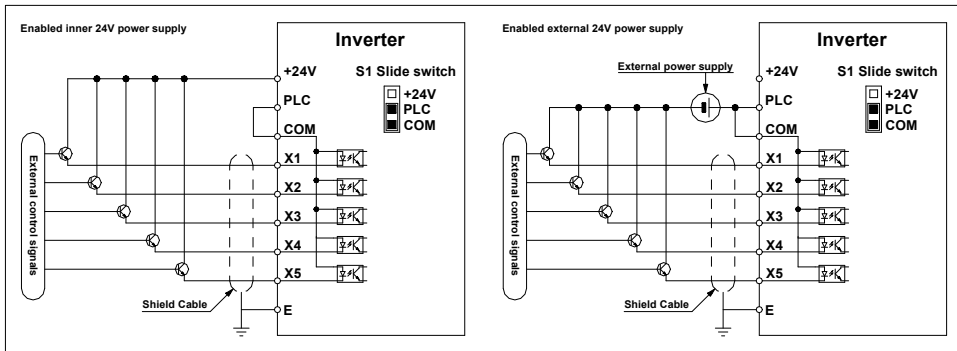

Connection mode of NPN characteristic transistor:

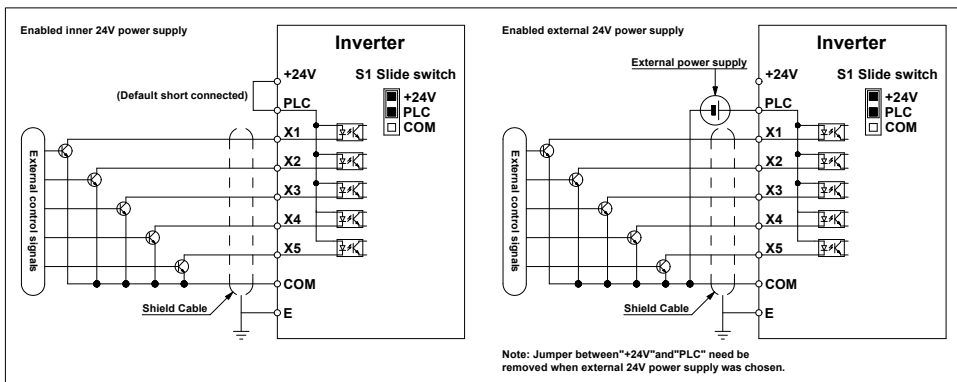

2.4 Product dimensions

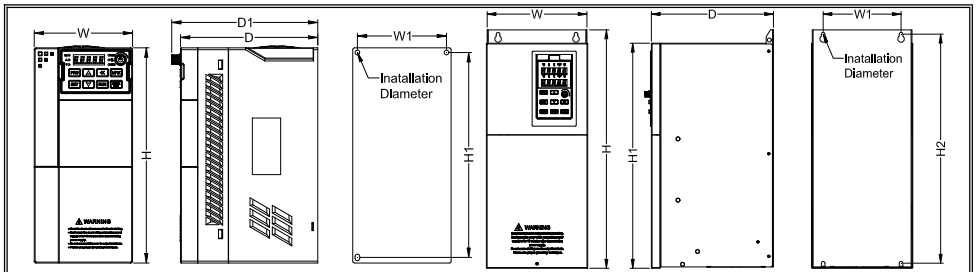

Inverter model	Dimensions (mm)				Installation (mm)		Mounting aperture
	W	H	D	D1	W1	H1	
XX-D1-R75G-B	89	190	135	144	79	180	M4×2
XX-D2-R75G-B							
XX-D2-1R5G-B							
XX-D3-R75G-B							
XX-D3-1R5G-B							
XX-D3-2R2G-B							
XX-D1-1R5G-B	106	230	148	157	96	219	M4×3
XX-D2-2R2G-B							
XX-D2-004G-B							
XX-D3-004G-B							
XX-D3-5R5G-B							
XX-D3-7R5G-B-E							
XX-D3-11G-B	130	275	160	169	115	260	M5×3
XX-D3-15G-B-E							
XX-D3-18G-B							
XX-D3-22G-B	155	335	191	200	141.5	320	M5×4
Inverter model	Dimensions (mm)				Installation (mm)		Mounting aperture
	W	H	H1	D	W1	H2	
XX-D3-30G	195	445	420	235	150	430	4-M6
XX-D 3-37G							
XX-D 3-45G	240	560	520	310	176	544	4-M6
XX-D 3-75G							
XX-D3-90G	270	640	582	350	200	620	4-M8
XX-D3-110G							

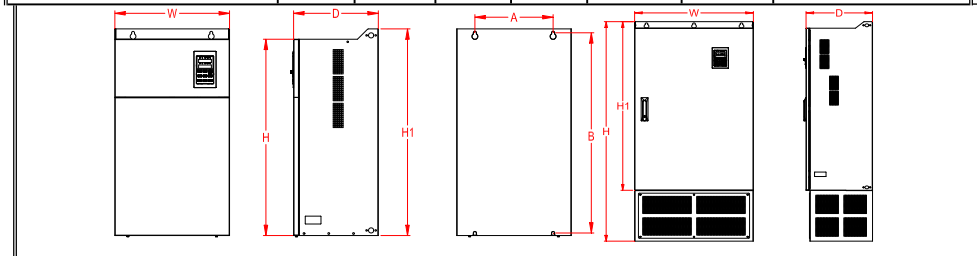

2.5 Keyboard size

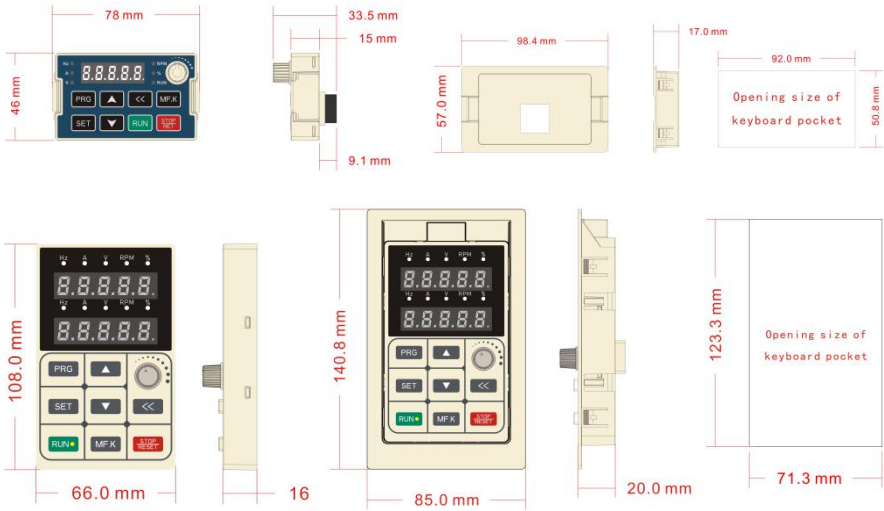

Chapter 3 Keyboard Layout and Operation Instructions

3.1 Keyboard appearance



3.2 Key function

symbols	Key name	Function description
	Menu	First level menu ,entry or exit
	Confirm / modify key	Enter the menu screen step by step and confirm the setting parameters
	Increasing key	Data or function code increment
	Decrement key	Data or function code decrement
	Run key	In keyboard operation mode, used for running operation
	Multi-function key	According to F4-07 parameter, the function switch can be selected, and the command source or running direction can be quickly switched.
	Stop / Reset button	In the running state, pressing this key is used to stop the operation; in case of fault alarm, it is used for reset operation. The characteristics of this key are restricted by F4-08 parameters.
	Shift key	In the display interface, cycle to select the display parameters; when modifying the parameters, it is used to switch the modification bits.
	Keyboard potentiometer	It can be used to set the input value of given frequency, given torque, PID given, PID feedback, etc.

3.3 Indicator light description

Name	State	Meaning	
Unit indicator	Hz	Flashing / On	Represents the unit of frequency
	A	On	Represents the unit of current
	V	Flashing / On	Represents a unit of voltage
	S	On	Represents the unit of time
	RPM	On	Represents the speed unit
	%	Flashing / On	Represents a percentage unit
Status Indicator	RUN	On	The Inverter is running forward
	RUN	Flashing	The inverter is in reverse operation
	RUN	Off	The inverter stops

Chapter 4 Function Parameter Table

This chapter just provides function parameter table.

Specifications refer to KV600 technical manual or inquiry the company.

4.1 Description of the meanings in the function code parameter brief table

- “●” : Parameter can be changed in the running state.
- “○” : Parameter can't be changed in the running state.
- “×” : Parameter can be read only.
- “ - ” : Factory setting parameter, only factory can set.
- “※” : Parameter is related to the model.

4.2 Basic parameters

NO.	Function description	Factory default	Range of settings and definition	Feature	Address
F0-00	G/P Model Setting	Model set	0:G Type 1:P Type	○	0x000
F0-01	Motor control mode	0	Asynchronous motor control mode: 0: V/F control Synchronous motor control mode: 3: High-performance VC without PG	○	0x001
F0-02	Run command channel	0	0: Keyboard control1: Terminal control 2: RS485 communication control 3: Optional card	○	0x002
F0-03	Main Frequency reference source A	0	0: Keyboard number given 1: potentiometer of keyboard given 2: Voltage/Current analog AI1 given 3: Voltage/Current analog AI2 given	●	0x003
F0-04	Auxiliary Frequency reference source B	1	4: Terminal pulse X5 given 5: RS485 communication given 6: Terminal UP/DW control 7: PID control given 8: Program control (PLC) given 9: Multi-steps speed given 10: Optional card	●	0x004
F0-05	The reference source selection of auxiliary frequency source B	0	0: Max. output frequency as reference source 1: Set frequency of channel A as reference source	●	0x005
F0-06	Frequency given source selection	0	0: Main Frequency reference source A 1: Auxiliary Frequency reference source B 2: A+B 3: A-B 4: Max. value of A and B 5: Min. value of A and B	●	0x006
F0-07	Running Command Binding	0000	Unit: keyboard command instruction binding Tens place: terminal command instruction binding Hundreds: communication command instruction binding Thousands: optional card command instruction binding 0: no binding 1: keyboard number given frequency 2: Potentiometer of keyboard given 3: Voltage/Current analog AI1 given	●	0x007

			4 : Voltage/Current analog AI2 given 5 : Terminal pulse X5 given 6 : RS485 communication given 7 : Terminal UP/DW control 8 : PID control given 9 : Program control (PLC) given A: Multi-steps speed given B: Optional card		
F0-08	Keyboard digital setting frequency	50.00Hz	0~upper limit	●	0x008
F0-09	Max frequency output	50.00Hz	upper limit~600.00Hz	○	0x009
F0-10	Upper limit frequency source selection	0	0: Upper limit frequency digital given 1: potentiometer of keyboard given 2: Voltage/Current analog AI1 given 3: Voltage/Current analog AI2 given 4: Terminal pulse X5 given 5: RS485 communication given 6: Optional card	●	0x00A
F0-11	Upper frequency limit digital setting	50.00Hz	Lower limit frequency~max frequency`	●	0x00B
F0-12	Lower limit frequency	0.00Hz	0.00~upper limit frequency	●	0x00C
F0-13	Lower limit frequency running mode	1	0: Stop output 1: Run at lower limit frequency	○	0x00D
F0-14	ACC time 0	Model set	0.01~650.00s	※	0x00E
F0-15	DEC time 0	Model set		※	0x00F
F0-16	Rotary direction selection	0000	Unit: running direction takes the opposite 0: Direction unchanged 1: Direction takes the opposite Tens : running direction prohibited 0:Forward and reverse commands are allowed 1: Only FWD command allowed 2: Only REV command allowed Hundreds:frequency control direction selection 0: Invalid 1: Valid Thousands: torque control direction selection 0: Invalid 1: Valid	○	0x010
F0-17	PWM carrier frequency	Model set	0.7~16.0kHz	※	0x011
F0-18	PWM control mode	1111	Unit: carrier associated with temperature 0: Temperature independent 1: Temperature dependent Tens : carrier associated with outputfrequency 0:not associated 1: associated Hundreds: random PWM valid 0: Prohibited 1: Valid Thousands: PWM modulation mode 0: Only use three-phase modulation 1: Two-phase and three-phase modulation automatically switched	●	0x012
F0-19	Parameter initialization	0	0: No action 1: Restore factory default (not restoring motor parameters) 2: Restore factory default (restoring motor parameters) 3: Clear malfunction records		0x013

F1 Start-stop control parameter group

NO.	Function description	Factory default	Range of settings and definition	Feature	Address
F1-00	Start-up running mode	0	0: Start by start-up frequency 1: DC Braking at first then start by start-up frequency 2: Speed tracking, and judge the direction then start	○	0x100
F1-01	Start pre-excitation time	0.00s	0.00~60.00s	○	0x101
F1-02	Start-up frequency	0.50Hz	0.00~60.00Hz	○	0x102
F1-03	Start-up frequency holding time	0.0s	0.0~50.0s	○	0x103
F1-04	Braking current before start	60.0%	0.0~150.0%	○	0x104
F1-05	Braking time before start	0.0s	0.0~60.0s	○	0x105
F1-06	Speed tracking time	0.50s	0.00~60.00s	○	0x106
F1-07	Speed tracking delay when stop	1.00s	0.00~60.00s	○	0x107
F1-08	Speed tracking Mode	0010	Unit: The frequency selection of Speed tracking 0: Speed tracking from Max.Output frequency 1: Speed tracking from stop Output frequency Tens :The direction selection of Speed tracking 0: bidirectional 1: Unidirectional	○	0x108
F1-09	Reserved	---	---	---	0x109
F1-10	Stop mode	0	0:DEC stop 1:Free stop	●	0x10A
F1-11	DC braking initial frequency when stop	1.00Hz	0.00~50.00Hz	○	0x10B
F1-12	DC braking current	60.0%	0.0~150.0%	●	0x10C
F1-13	DC braking hold time when stop	0.0s	0.0~60.0s	○	0x10D
F1-14	Stop detection frequency	0.50Hz	0.00~50.00Hz	●	0x10E
F1-15	Reserved	---	---	---	0x10F
F1-16	ACC/DEC selection	0010	Unit: time base selection 0: max frequency 1: fixed frequency 50Hz 2: set frequency Tens : S ACC/DEC selection 0: Beeline ACC/DEC 1: S Curve ACC/DEC Hundreds &Thousands: reserved	○	0x110
F1-17	ACC start time for S curve	0.10s	0.00~10.00	○	0x111
F1-18	ACC end time for S curve	0.10s	0.00~10.00	○	0x112
F1-19	DEC start time for S curve	0.10s	0.00~10.00	○	0x113
F1-20	DEC end time for S curve	0.10s	0.00~10.00	○	0x114
F1-21	ACC time 1	10.00s	0.01~650.00s	●	0x115
F1-22	DEC time 1	10.00s	0.01~650.00s	●	0x116
F1-23	ACC time 2	10.00s	0.01~650.00s	●	0x117
F1-24	DEC time 2	10.00s	0.01~650.00s	●	0x118

F1-25	ACC time 3	10.00s	0.01~650.00s	●	0x119
F1-26	DEC time 3	10.00s	0.01~650.00s	●	0x11A
F1-27	DEC time at emergency stop	1.00s	0.01~650.00s	●	0x11B
F1-28	FWD&REV dead time	0.0s	0.0~120.0s	○	0x11C
F1-29	Zero speed torque frequency threshold	0.50Hz	0.00~10.00Hz	●	0x11D
F1-30	Zero speed torque coefficient	60.0%	0.0~150.0%	●	0x11E
F1-31	Zero speed torque holding time	0	0.0~6000.0s If set 6000.0S,always hold without time limit	●	0x11F
F1-32~F1-34		Reserved			
F1-35	Power off restart action selection	0	0:Invalid1:Valid	○	0x123
F1-36	Power off restart waiting time	0.50s	0.00~60.00s	○	0x124
F1-37	JOG runningcurvesetting	1	0:S curve 1:Beeline	○	0x125
F1-38	JOG running frequency setting	5.00Hz	0.00~Max frequency	●	0x126
F1-39	JOG ACC time	10.00s	0.01~650.00s	●	0x127
F1-40	JOG DEC time	10.00s	0.01~650.00s	●	0x128

F2 Multi-function terminal parameter group

NO.	Function description	Factory default	Range of settings and definition	Feature	Address
F2-00	X1 terminal function selection	1	0: No function 1: Forward 2: Reverse 53: Water fulfilled detect alarm 54:Water fulfilled detect reset	○	0x200
F2-01	X2 terminal function selection	2		○	0x201
F2-02	X3 terminal function selection	53		○	0x202
F2-03	X4 terminal function selection	54		○	0x203
F2-04	X5 terminal function selection	5	Refer to attached list 4.3	○	0x204
F2-05	X6 terminal function selection	6	Refer to attached list 4.3(X6 expand)	○	0x205
F2-06	X7 terminal function selection	7	Refer to attached list 4.3(X7 expand)	○	0x206
F2-07	X8 terminal function selection	8	Refer to attached list 4.3(X8 expand)	○	0x207
F2-08	X1~X4 terminal characteristics selection	0000	0: closed effective 1: open effective Unit: X1 Tens : X2 Hundreds: X3 Thousands: X4	●	0x208
F2-09	X5~X8 terminal characteristics selection	0000	0: closed effective 1: open effective Unit: X5 Tens : X6 Hundreds: X7 Thousands: X8	●	0x209
F2-10	X1 valid detection delay	0.010	0.000~6.000s	●	0x20A
F2-11	X1 invalid detection delay	0.010	0.000~6.000s	●	0x20B
F2-12	X2 valid detection delay	0.010	0.000~6.000s	●	0x20C
F2-13	X2 invalid detection delay	0.010	0.000~6.000s	●	0x20D
F2-14	X3 valid detection delay	0.010	0.000~6.000s	●	0x20E
F2-15	X3 invalid detection delay	0.010	0.000~6.000s	●	0x20F

F2-16	X4 valid detection delay	0.010	0.000~6.000s	●	0x210
F2-17	X4 invalid detection delay	0.010	0.000~6.000s	●	0x211
F2-18	X5 valid detection delay	0.010	0.000~6.000s	●	0x212
F2-19	X5 invalid detection delay	0.010	0.000~6.000s	●	0x213
F2-20	X6 valid detection delay	0.010	0.000~6.000s	●	0x214
F2-21	X6 invalid detection delay	0.010	0.000~6.000s	●	0x215
F2-22	X7 valid detection delay	0.010	0.000~6.000s	●	0x216
F2-23	X7 invalid detection delay	0.010	0.000~6.000s	●	0x217
F2-24	X8 valid detection delay	0.010	0.000~6.000s	●	0x218
F2-25	X8 invalid detection delay	0.010	0.000~6.000s	●	0x219
F2-26	Terminal control running mode	0	0: two-wire system 1 1: two-wire system 2 2: Three-wire system 1 3: three-wire system 2	●	0x21A
F2-27	Terminal operate protection	0000	0: off1: open Unit : terminal start protection when exiting abnormally Tens : Jog terminal start protection when abnormal exit Hundreds : start protection when command channel is switched to terminal Thousands : reserved	○	0x21B
F2-28	X5 input minimum frequency	0.00kHz	0.00~50.00kHz	●	0x21C
F2-29	X5 min frequency corresponding setting	0.00%	0.00~100.00%	●	0x21D
F2-30	X5 input max frequency	50.00kHz	0.00~50.00kHz	●	0x21E
F2-31	X5 max frequency corresponding setting	100.00%	0.00~100.00%	●	0x21F
F2-32	X5 filter time	0.100s	0.000~9.000s	●	0x220
F2-33	X5 cutoff frequency	0.010kHz	0.000~1.000kHz	●	0x221
F2-34	UP/DW terminal control mode	0	0: Frequency power-down storage 1: Frequency is not stored when power is off 2: Adjustable during operation, reset when shutdown	○	0x222
F2-35	Terminal UP / DW control frequency rate	0.50Hz/s	0.01~50.00Hz/s	●	0x223
F2-36	Reserved	---	---	---	0x224
F2-37	Timer time unit	0	0:Second 1:Minute 2:Hour	●	0x225
F2-38	Timer setting value	0	0~65000	●	0x226
F2-39	Reserved	---	---	---	0x227
F2-40	Counter input frequency	0	0~6000		0x228
F2-41	Counter max value	1000	0~65000	●	0x229
F2-42	Counter setting value	500	0~65000	●	0x22A
F2-43	Reserved	---	---	---	0x22B
F2-44	Output terminal polarity selection	0000	0: positive polarity1: negative polarity Unit :Y terminal Tens :Relay 1 Hundreds :Relay 2 Thousands :Reserved		0x22C
F2-45	Y output terminal	1	Refer to attached list 4.4	●	0x22D
F2-46	Relay 1 output	4	Refer to attached list 4.4	●	0x23E

F2-47	Relay 2 output	11	Refer to attached list 4.4	●	0x23F
F2-48	Y output delay time	0.010s	0.000~6.000s	●	0x230
F2-49	Relay 1 output delay	0.010s	0.000~6.000s	●	0x231
F2-50	Relay 2 output delay	0.010s	0.000~6.000s	●	0x232
F2-51	Output frequency level 1(FDT1)	30.00Hz	0.00~Max. frequency	●	0x233
F2-52	FDT1 lag	1.00Hz	0.00~Max. frequency	●	0x234
F2-53	Output frequency level 1(FDT2)	50.00Hz	0.00~Max. frequency	●	0x235
F2-54	FDT2 lag	1.00Hz	0.00~Max. frequency	●	0x236
F2-55	Detected value reaches the given frequency	2.00Hz	0.00~50.00Hz	●	0x237

F3 Analog terminal parameter group

NO.	Function description	Factory default	Range of settings and definition	Feature	Address
F3-00	AI1 Lower limit	0.00V	0.00~10.00V	●	0x300
F3-01	AI1 Lower limit	0.00%	-100.00~100.00%	●	0x301
F3-02	AI1 Lower limit corresponding setting	10.00V	0.00~10.00V	●	0x302
F3-03	AI1 upper limit	100.00%	-100.00~100.00%	●	0x303
F3-04	AI1 upper limit corresponding setting	0.010s	0.000~6.000s	●	0x304
F3-05	AI1 voltage / current selection	0	0: voltage1: current	●	0x305
F3-06	AI2 Lower limit	0.00V	-10.00V~10.00V	●	0x306
F3-07	AI2 Lower limit corresponding setting	0.00%	-100.00~100.00%	●	0x307
F3-08	AI2 upper limit	10.00V	-10.00V~10.00V	●	0x308
F3-09	AI2 upper limit corresponding setting	100.00%	-100.00~100.00%	●	0x309
F3-10	AI2 filter time	0.010s	0.000~6.000s	●	0x30A
F3-11	AI2 voltage / current selection	0	0: voltage1: current	●	0x30B
F3-12	AI1 terminal function	0	Refer to attached list 4.3	○	0x30C
F3-13	AI1 high level setting	70.00%	0.00~100.00%	●	0x30D
F3-14	AI1 low level setting	30.00%	0.00~100.00%	●	0x30E
F3-15	AI2 terminal function	0	Refer to attached list 4.3	○	0x30F
F3-16	AI2 high level setting	70.00%	0.00~100.00%	●	0x310
F3-17	AI2 low level setting	30.00%	0.00~100.00%	●	0x311
F3-18	Valid state setting when analog used as terminal	0000	0: low level 1: high level Unit: AI1 Tens: AI2	●	0x312
F3-19	Analog input curve selection	0000	0: Beeline (default) 1: curve 1 2: curve 2 Unit: AI1 Tens: AI2	●	0x313
F3-20	Reserved	---	---	---	0x314
F3-21	Curve 1 lower limit	0.00V	0.00~10.00V	●	0x315
F3-22	Curve 1 lower limit	0.0%	0.00~100.00%	●	0x316
F3-23	Curve 1 inflection point 1 input voltage	3.00V	0.00~10.00V	●	0x317

F3-24	Curve 1 inflection point 1	30.00%	0.00~100.00%	●	0x318
F3-25	Curve 1 inflection point 2	6.00V	0.00~10.00V	●	0x319
F3-26	Curve 1 inflection point 2 corresponding setting	60.00%	0.00~100.00%	●	0x31A
F3-27	Curve 1 upper limit	10.0V	0.00~10.00V	●	0x31B
F3-28	Curve 1 upper limit corresponding setting	100.00%	0.00~100.00%	●	0x31C
F3-29	Curve 2 lower limit	0.00V	0.00~10.00V	●	0x31D
F3-30	Curve 2 lower limit	0.00%	0.00~100.00%	●	0x31E
F3-31	Curve 2 inflection point 1 input voltage	3.00V	0.00~10.00V	●	0x31F
F3-32	Curve 2 inflection point 1 corresponding setting	30.00%	0.00~100.00%	●	0x320
F3-33	Curve 2 inflection point 2 input voltage	6.00V	0.00~10.00V	●	0x321
F3-34	Curve 2 inflection point 2 corresponding setting	60.00%	0.00~100.00%	●	0x322
F3-35	Curve 2 upper limit	10.00V	0.00~10.00V	●	0x323
F3-36	Curve 2 upper limit corresponding setting	100.00%	0.00~100.00%	●	0x324
F3-37	A0 output signal selection	0000	Unit: AO 0: 0~10V 1: 4.00~20.00mA 2: 0.00~20.00mA 3: FM frequency pulse output Tens : AO (extended card) 0: 0~10V 1: 4.00~20.00mA 2: 0.00~20.00mA	●	0x325
F3-38	A0 output selection	0	0:Given frequency 1:Output frequency 2:Output current 3:Input voltage 4:Output voltage	●	0x326
F3-39	A0(extended card) output selection	1	5:Machine speed 6:Given torque 7:Output torque 8:PID given value 9:PID feedback value 10:Output power 11:Bus voltage 12:AI1 13:AI2 14:X5 input value 15,16:I _{GBT} temperature 1,2 17:RS485 given	●	0x327
F3-40	A0output gain	100.0%	25.0~200.0%	●	0x328
F3-41	A0 analog outputsignal bias	0.0%	-10.0~10.0%	●	0x329
F3-42	A0output filter	0.010s	0.000~6.000s	●	0x32A
F3-43	A0(extended card) output gain	100.0%	25.0~200.0%	●	0x32B

F3-44	A0(extended card) analog output signal bias	0.0%	-10.0%~10.0%	●	0x32C
F3-45	A0(extended card) output filter	0.010s	0.000~6.000s	●	0x32D
F3-46	A0 FM frequency output lower limit	0.20kHz	0.00~100.00kHz	●	0x32E
F3-47	A0FM frequency output upper limit	50.00kHz	0.00~100.00kHz	●	0x32F

F4 System parameters

NO.	Function description	Factory default	Range of settings and definition	Feature	Addresses
F4-00	Parameter and key lock selections	0	0: Not locked 1: Function parameter locked 2: Function parameter and key locked (except for RUN/STOP/JOG) 3: All function parameter and key locked	●	0x400
F4-01	User password	0	0~9999	●	0x401
F4-07	Keyboard MF.K selection	0	0: REV 1: JOG	○	0x407
F4-08	STOP key setting	1	0: Non-keyboard control mode is invalid 1: Non-keyboard control mode stops according to stop mode 2: Non-keyboard control mode stop according to free stop mode	○	0x408
F4-09	UP/DOWN key selection	0011	Unit: keyboard UN/DOWN key modify selection 0: Invalid 1: Modify frequency setting by key board numbers F0-08 2: Modify PID give setting by key board numbers FB-01 Tens :power off storage selection 0: No save frequency after power off 1: Save frequency after power off Hundreds : action limit 0: Operation stop for adjusting 1: Adjusting only in operation, stop for holding 2: Adjusting in operation, stop for clearing	○	0x409
F4-10	Keyboard potentiometer lower limit	0.50V	0.00~5.00V	●	0x40A
F4-11	Corresponds to the lower limit of the keyboard	0.00	0.00~100.00%	●	0x40B
F4-12	Keyboard potentiometer upper limit	4.50V	0.00~5.00V	●	0x40C
F4-13	Keyboard potentiometer upper limit correspondence	100.00	0.00~100.00%	●	0x40D
F4-14	The display content of the first line in running state	1101	Unit and Tens: display the first group 00~63 Hundreds and Thousands: display the second group 00~63	●	0x40E
F4-15	The display content of the first line in running state	0402	Same as F4-14	●	0x40F
F4-16	The display content of the first line in stop state	1100	Same as F4-14	●	0x410

F4-17	The display content of the first line in stop state	0402	Same as F4-14	●	0x411
F4-18	The display content of the second line in running state	0402	Same as F4-14	●	0x412
F4-19	The display content of the second line in running state	1210	Same as F4-14	●	0x413
F4-20	The display content of the second line in stop state	0402	Same as F4-14	●	0x414
F4-21	The display content of the second line in stop state	1210	Same as F4-14	●	0x415
F4-22	Keyboard display item setting	0000	Unit: output frequency selection 0: Aim frequency 1: Running frequency Hundreds: power display dimension 0: Power display percentage (%) 1: Power display kilowatt (KW)	●	0x416
F4-24	Rotate speed display	100.0%	0.0~500.0%	●	0x418
F4-25	Power display coefficient	100.0%	0.0~500.0%	●	0x419

F5 Motor parameter group

NO.	Function description	Factory default	Range of settings and definition	Feature	Address
F5-00	Motor mode	0	0: Asynchronous motors (AM) 1: Permanent magnet synchronous motors (PM)	×	0x500
F5-01	Number of motor poles	4	2~98	○	0x501
F5-02	Motor rated power	Model set	0.1~1000.0kW	※	0x502
F5-03	Motor rated frequency	Model set	0.01~max frequency	※	0x503
F5-04	Motor rated speed	Model set	1~65000rpm	※	0x504
F5-05	Motor rated voltage	Model set	0~1500V	※	0x505
F5-06	Motor rated current	Model set	0.1~2000.0A	※	0x506
F5-07	Asynchronous motor no-load current	Model set	0.1~650.0A	※	0x507
F5-08	Asynchronous motor stator resistance	Model set	0.01~50.00%	※	0x508
F5-09	Asynchronous motor rotor resistance	Model set	0.01~50.00%	※	0x509
F5-10	Asynchronous motor stator inductance	Model set	0.01~50.00%	※	0x50A
F5-11	synchronous motor stator resistance	Model set	0.1~2000.0%	※	0x50B
F5-12	Synchronous machine d axis inductance	Model set	0.01~50.00%	※	0x50C
F5-13	Synchronous machine q axis inductance	Model set	0.01~200.00%	※	0x50D
F5-14	Synchronous machine back EMF	Model set	0.01~200.00%	※	0x50E
F5-15	Synchronous machine encoder installation angle	Model set	1~1500V	※	0x50F
F5-16	Asynchronous motor stator inductance	Model set	0.00~360.00	※	0x510

F5-20	Motor parameters self-adjustment selections Motor auto tuning	0	0: No operation 1: Rotary type self-tuning 2: Static type self-tuning 3: Stator resistance self-tuning	○	0x514
F5-21	Synchronous machine poles searching function	0010	Unit: closed-loop vector 0: OFF 1: ON 2: On, only operate firstly when electrify Tens: open-loop vector 0: OFF 1: ON 2: ON, only operate firstly when electrify	○	0x515

F8 V/F control parameter group

NO.	Function description	Factory default	Range of settings and definition	Feature	Address
F8-00	Linear V/F curve selection	0	0: Beeline VF curve 1-9: 1.1-1.9 power VF curve 10: square VF curve 11: Multi-point V / F (F8-01~F8-10);	○	0x080
F8-01	V / F voltage V1	3.0%	0.0~100.0%	○	0x0801
F8-02	V / F frequency F1	1.00Hz	0.00~max frequency	○	0x0802
F8-03	V / F voltage V2	28.0%	0.0~100.0%	○	0x0803
F8-04	V / F frequency F2	10.00Hz	0.00~max frequency	○	0x0804
F8-05	V / F voltage V3	55.0%	0.0~100.0%	○	0x0805
F8-06	V / F frequency F3	25.00Hz	0.00~max frequency	○	0x0806
F8-07	V / F voltage V4	78.0%	0.0~100.0%	○	0x0807
F8-08	V / F frequency F4	37.50Hz	0.00~max frequency	○	0x0808
F8-09	V / F voltage V5	100.0%	0.0~100.0%	○	0x0809
F8-10	V / F frequency F5	50.00Hz	0.00~max frequency	○	0x080A
F8-11	Output voltage percentage	100.0%	25.0~120.0%	○	0x080B
F8-12	Torque boost	1.0%	0.0~30.0%	●	0x080C
F8-13	Torque boost cut-off frequency	50.0%	0.0~100.0%	●	0x080D
F8-14	V / F slip compensation gain	100.0%	0.0~200.0%	●	0x080E
F8-15	V / F slip compensation limit	100.0%	0.0~300.0%	●	0x080F
F8-16	V / F slip compensation	0.200s	0.000~6.000s	●	0x0810
F8-17	Oscillation suppression gain	100.0%	0.0~900.0%	●	0x0811
F8-18	Reserved	---	---	--	0x0812
F8-19	V / F automatic energy saving control	0	0: off 1:on	○	0x0813
F8-20	Lower limit of energy-saving step-down frequency	15.00Hz	0.0~50.00Hz	○	0x0814
F8-21	Energy-saving step-down voltage lower limit	50.0%	20.0~100.0%	○	0x0815
F8-22	Energy-saving buck voltage regulation rate	0.010V/MS	0.000~0.200V/MS	●	0x0816
F8-23	Energy saving buck voltage pick-up rate	0.200V/MS	0.000~2.000V/MS	●	0x0817
F8-24~F8-29	Reserved				

F8-30	Output voltage source of voltage-frequency separation	0	0: function code F8-31 setting 1: potentiometer of keyboard given 2: AI1 3: AI2 4:X5 5: PID output 6: RS485	●	0x081E
F8-31	Output voltage source of voltage-frequency separation number setting	0.0%	0.0%~100.0%	●	0x081F
F8-32	Output voltage source of voltage-frequency separation ACC time	10.00s	0.0~100.00s	●	0x0820
F8-33	Output voltage source of voltage-frequency separation DEC time	10.00s	0.0~100.00s	●	0x0821
F8-34	voltage-frequency separation stop time	0	0: Output voltage and frequency ACC/DEC no interaction 1: Output voltage down to 0V, then output frequency start to decrease	●	0x0822

F9 Enhanced Function Parameter Group

NO.	Function description	Factory default	Range of settings and definition	Feature	Address
F9-00	Jump frequency 1	0.00Hz	0.00~max frequency	●	0x0900
F9-01	Jump frequency amplitude 1	0.00Hz	0.00~max frequency	●	0x0901
F9-02	Jump frequency 2	0.00Hz	0.00~max frequency	●	0x0902
F9-03	Jump frequency amplitude 2	0.00Hz	0.00~max frequency	●	0x0903
F9-04~F9-07		Reserved			
F9-08	Swing frequency control	0	0: invalid 1: valid	●	0x0908
F9-09	Swing frequency amplitude control	0	0: relative center frequency 1: Relative maximum frequency	●	0x0909
F9-10	Reserved				
F9-11	Swing frequency amplitude	10.0%	0.0~100.0%	●	0x090B
F9-12	Kick frequency amplitude	10.0%	0.0~50.0%	●	0x090C
F9-13	Swing frequency ACC time	5.00s	0.00~650.00s	●	0x090D
F9-14	Swing frequency DEC time	5.00s	0.00~650.00s	●	0x090E
F9-15	Fan control	1	0: Fan runs after inverter is powered on 1: Shutdown is related to temperature, and running is running 2: The shutdown fan stops, and the operation is related to temperature	●	0x090F
F9-16	Energy consumption braking enabled	0	0: OFF 1: ON	●	0x0910
F9-17	Energy consumption braking action voltage	135.0%	115.0%~150.0%	●	0x0911
F9-18	Energy use brake usage	10.0%	0.0~100.0%	●	0x0912
F9-19~F9-20		Reserved			

FA Protection and Malfunction Parameter Group

NO.	Function description	Factory default	Range of settings and definition	Feature	Address
FA-00	OC suppression function	0	0: Suppression valid 1: ACC/DEC valid, constant speed invalid	○	0xA00
FA-01	OC suppression point	160.0%	0.0 ~ 300.0%	●	0xA01
FA-02	OC suppression gain	100.0%	0.0 ~ 500.0%	●	0xA02
FA-03	Current hardware protection settings	0001	Unit: CBC(cycle by cycle, limit current according to its waveform) 0: off 1: on Tens: OC protection interference suppression 0: off 1: First grade 2: Second grade Hundreds: SC protection interference suppression 0: off 1: First grade 2: Second grade Thousands: Reserved	○	0xA03
FA-04 ~ FA-05		Reserved			
FA-06	Bus over voltage suppression function	0012	Unit: Over voltage suppression 0: Invalid 1: Valid in DEC 2: Valid both in ACC/DEC Tens: Over-excitation control 0: off 1: on Hundreds and Thousands: Reserved	○	0xA06
FA-07	Bus over voltage suppression	130.0%	110.0 ~ 150.0%	※	0xA07
FA-08	Bus over voltage suppression gain	100.0%	0.0 ~ 500.0%	●	0xA08
FA-09	Bus under voltage suppression function	0	0: Invalid 1: Valid	○	0xA09
FA-10	Bus under voltage suppression point	80.0%	60.0 ~ 90.0%	※	0xA0A
FA-11	Bus under voltage suppression gain	100.0%	0.0 ~ 500.0%	●	0xA0B
FA-12	Bus under voltage protection point	60.0%	60.0 ~ 90.0%	※	0xA0C
FA-13	Reserved	---	---	---	0xA0D
FA-14	Short-circuit detection after power on	0	0: off 1: on	○	0xA0E
FA-15	phase missing protection	0011	Unit: Output phase missing protection 0: off 1: on Tens: Input phase missing protection 0: off 1: Open Alarm 2: Open Fault(STOP VFD) Hundreds and Thousands: Reserved	●	0xA0F
FA-16	Motor overload protection curve coefficient	100.0%	0.0 ~ 250.0%	●	0xA10

FA-17	Load warning checkout setting	0000	Unit: checkout selection (protection 1) 0: No detection 1: detection load is too large 2: Only at constant speed detects excessive load 3: detection of insufficient load 4: Detects insufficient load only at constant speed Tens: Alarm selection 0: Alarm, continue running 1: fault protection action and free stop Hundreds: Check Out Selection (Protection 2) 0: No detection 1: detection load is too large 2: Only at constant speed detects excessive load 3: detection of insufficient load 4: Detects insufficient load only at constant speed Thousands: Alarm selection 0: Alarm, continue running 1: fault protection action and free stop	○	0xA11
FA-18	Load early detection level 1	130.0%	0.0~200.0%	○	0xA12
FA-19	Load warning detection time 1	5.0s	0.0~60.0s	○	0xA13
FA-20	Load early detection level 2	30.0%	0.0~200.0%	○	0xA14
FA-21	Load warning detection time 2	5.0s	0.0~60.0s	○	0xA15
FA-22	Reserved	---	---	---	0xA16
FA-23	Protection action of speed bias excess	0000	Unit: Detection selection 0: Not detected 1: Detected only at constant speed 2: Detecting Tens: Alarm selection 0: Free stop and report fault 1: Alarm and continue operation Hundreds and Thousands: Reserved	○	0xA17
FA-24	Detection threshold when speed bias excess	10.0%	0.0~60.0%	○	0xA18
FA-25	Detection time when speed bias excess	2.0s	0.0~60.0s	○	0xA19
FA-26	Rapid protection action	0000	Unit : checkout selection 0: No detection 1: only at constant speed 2: Always detect Tens : Alarm selection 0: Free stop and report fault 1: Alarm and continue operation Hundreds and thousands: reserved	○	0xA1A
FA-27	Fast detection threshold	110.0%	0.0~150.0%	○	0xA1B
FA-28	Fast detection time	0.010s	0.000~2.000s	○	0xA1C
FA-29~FA-36		Reserved			
FA-37	Failure self-recovery times	0	0~5	○	0xA25

FA-38	Failure self-recovery interval	1.0s	0.1~100.0s	○	0xA26
FA-39	Troubleshooting information	--	See fault message code table for details	×	0xA27
FA-40	Fault type	--	See fault message code table for details	×	0xA28
FA-41	Fault operating frequency	--	0.00~Max frequency	×	0xA29
FA-42	Fault output voltage	--	0~1500V	×	0xA2A
FA-43	Fault output current	--	0.1~2000.0A	×	0xA2B
FA-44	Fault bus voltage	--	0~3000V	×	0xA2C
FA-45	Failure module temperature	--	0~100℃	×	0xA2D
FA-46	Fault inverter status	--	Unit : running direction 0: forward1: reverse Tens : running status 0: shutdown1: speed up 2: slowdown3: constant speed Hundreds and thousands: reserved	×	0xA2E
FA-47	Fault input terminal status	--	See input terminal state diagram	×	0xA2F
FA-48	Fault output terminal status	--	See output terminal state diagram	×	0xA30
FA-49	Previous failure type	--	See fault message code table for details	×	0xA31
FA-50	Frequency of previous fault	--	0.00~Max frequency	×	0xA32
FA-51	Last fault output voltage	--	0~1500V	×	0xA33
FA-52	Last fault output current	--	0.1~2000.0A	×	0xA34
FA-53	Last faulted bus voltage	--	0~3000V	×	0xA35
FA-54	Last failed module	--	0~100℃	×	0xA36
FA-55	Status of the previous fault inverter	--	Unit : running direction 0: forward1: reverse Tens : running status 0: shutdown1: steady speed 2: speed up3: slow down Hundreds and thousands: reserved	×	0xA37
FA-56	Last fault input terminal status	--	See input terminal state diagram	×	0xA38
FA-57	Last fault output terminal status	--	See output terminal state diagram	×	0xA39
FA-58	First two failure types	--	See fault message code table for details	×	0xA3A
FA-59	First three failure types	--	See fault message code table for details	×	0xA3B

Fb PID control parameter group

NO.	Function description	Factory default	Range of settings and definition	Feature	Address
Fb-00	PID controller given signal source	0	0: Keyboard numeric PID given 1: keyboard potentiometer given 2: AI1 given 3:AI2 4: Pulse X5 given 5: RS485 communication given 6:Optional card 7:terminal selection	●	0xB00
Fb-01	Keyboard digit PID given / feedback	50.0%	0.00~100.0%	●	0xB01
Fb-02	PID given changing time	1.00s	0.00~60.00s	●	0xB02

Fb-03	PID controller feedback signal source	2	0: Keyboard numeric PID given 1: keyboard potentiometer given 2: AI1 given 3:AI2 4: Pulse X5 given 5: RS485 communication given 6:Optional card 7:terminal selection	●	0xB03
Fb-04	Feedback signal filter time	0.010s	0.000~6.000s	●	0xB04
Fb-05	Feedback signal gain	1.00	0.00~10.00	●	0xB05
Fb-06	Maximum feedback signal	100.0	0~100.0	●	0xB06
Fb-07	PID control selection	0100	Unit : feedback characteristic selection 0: Positive characteristic 1: negative characteristics Tens : closed-loop bypass hold output 0: Output is cleared when closed loop bypass 1: Output hold when closed loop bypass Hundreds : alignment selection 0: non-center aligned 1: center-aligned Thousands : Differential Adjustment Properties 0: Differentiate the deviation 1: Differentiate feedback	○	0xB07
Fb-08	PID preset output	100.0%	0.0~100.0%	●	0xB08
Fb-09	PID preset output running	0.0s	0.0~6500.0s	●	0xB09
Fb-10	PID control deviation limit	0.0%	0.0~100.0%	●	0xB0A
Fb-11	Proportional gain P1	0.100	0.000~8.000	●	0xB0B
Fb-12	Integration time I1	1.0s	0.0~600.0s	●	0xB0C
Fb-13	Differential time D1	0.000s	0.000~6.000s	●	0xB0D
Fb-14	Proportional gain P2	0.100	0.000~8.000	●	0xB0E
Fb-15	Integration time I2	1.0s	0.0~600.0s	●	0xB0F
Fb-16	Differential time D2	0.000s	0.000~6.000s	●	0xB10
Fb-17	PID Parameter switching condition	0	0: No switch 1: X terminal switching 2: switch based on deviation	●	0xB11
Fb-18	Low value of switching deviation	20.0%	0.0~100.0%	●	0xB12
Fb-19	High value of switching deviation	80.0%	0.0~100.0%	●	0xB13
Fb-21	Differential limit	5.0%	0.0~100.0%	●	0xB15
Fb-22	PID output upper limit	100.0%	0.0~100.0%	●	0xB16
Fb-23	PID output lower limit	0.0%	0.0~[Fb-22]	●	0xB17
Fb-24	PID output filter time	0.0s	0.000~6.000s	●	0xB18
Fb-25	Feedback wire break detection time	1.0s	0.0~120.0s	●	0xB19
Fb-26	Feedback wire break action selection	0	0: Continue without failure 1: Stop and report failure 2: keep running, output alarm 3: Run at current frequency and alarm	●	0xB1A

Fb-27	Wire break alarm upper limit	100.0%	0.0~100.0%	●	0xB1B
Fb-28	Wire break alarm lower limit	0.0%	0.0~100.0%	●	0xB1C
Fb-29	Dormancyselection	0	0:OFF 1:ON	●	0xB1D
Fb-30	Dormant frequency	30.00Hz	0.00~50.00Hz	●	0xB1E
Fb-31	Dormant delay time	3.0S	0.0~3600.0S	●	0xB1F
Fb-32	Wake-up bias	5.0%	0.0~50.0%	●	0xB20
Fb-33	Wake-up delay	0.0S	0.0~60.0S	●	0xB21

FC Multi-speed, PLC function parameter group

NO.	Function description	Factory default	Range of settings and definition	Feature	Address
FC-00	Multi-speed frequency 1	10.00Hz	0.00~Max frequency	●	0xC00
FC-01	Multi-speed frequency 2	20.00Hz	0.00~Max frequency	●	0xC01
FC-02	Multi-speed frequency 3	30.00Hz	0.00~Max frequency	●	0xC02
FC-03	Multi-speed frequency 4	40.00Hz	0.00~Max frequency	●	0xC03
FC-04	Multi-speed frequency 5	50.00Hz	0.00~Max frequency	●	0xC04
FC-05	Multi-speed frequency 6	40.00Hz	0.00~Max frequency	●	0xC05
FC-06	Multi-speed frequency 7	30.00Hz	0.00~Max frequency	●	0xC06
FC-07	Multi-speed frequency 8	20.00Hz	0.00~Max frequency	●	0xC07
FC-08	Multi-speed frequency 9	10.00Hz	0.00~Max frequency	●	0xC08
FC-09	Multi-speed frequency 10	20.00Hz	0.00~Max frequency	●	0xC09
FC-10	Multi-speed frequency 11	30.00Hz	0.00~Max frequency	●	0xC0A
FC-11	Multi-speed frequency 12	40.00Hz	0.00~Max frequency	●	0xC0B
FC-12	Multi-speed frequency 13	50.00Hz	0.00~Max frequency	●	0xC0C
FC-13	Multi-speed frequency 14	40.00Hz	0.00~Max frequency	●	0xC0D
FC-14	Multi-speed frequency 15	30.00Hz	0.00~Max frequency	●	0xC0E
FC-15	Multi-speed frequency running mode selection	0000	Unit: cycle mode 0: Stop after single cycle 1: Continuous cycles 2: Keep final value after single cycle Tens: Time unit 0: second 1: minute 2:hour Hundreds: Power down memory 0: Not save 1: save Thousands: Start mode 0: Restart from the 1st stage 1: Restart from the stop stage 2: Continue running from the time when stop	●	0xC0F
FC-16	Multi-speed 1 running time	10.0	0.0~6500.0(s/m/h)	●	0xC10
FC-17	Multi-speed2running time	10.0	0.0~6500.0(s/m/h)	●	0xC11
FC-18	Multi-speed 3running time	10.0	0.0~6500.0(s/m/h)	●	0xC12
FC-19	Multi-speed4running time	10.0	0.0~6500.0(s/m/h)	●	0xC13
FC-20	Multi-speed5running time	10.0	0.0~6500.0(s/m/h)	●	0xC14
FC-21	Multi-speed6running time	10.0	0.0~6500.0(s/m/h)	●	0xC15
FC-22	Multi-speed7running time	10.0	0.0~6500.0(s/m/h)	●	0xC16
FC-23	Multi-speed 8running time	10.0	0.0~6500.0(s/m/h)	●	0xC17
FC-24	Multi-speed9running time	10.0	0.0~6500.0(s/m/h)	●	0xC18

FC-25	Multi-speed10running time	10.0	0.0~6500.0(s/m/h)	●	0xC19
FC-26	Multi-speed 11running time	10.0	0.0~6500.0(s/m/h)	●	0xC1A
FC-27	Multi-speed12running time	10.0	0.0~6500.0(s/m/h)	●	0xC1B
FC-28	Multi-speed 13running time	10.0	0.0~6500.0(s/m/h)	●	0xC1C
FC-29	Multi-speed14running time	10.0	0.0~6500.0(s/m/h)	●	0xC1D
FC-30	Multi-speed15running time	10.0	0.0~6500.0(s/m/h)	●	0xC1E
FC-31	Multi- speed frequency 1-15 direction and ACC/DEC time	0000	Unit : the running direction of this paragraph 0: forward1: reverse Tens : ACC / DEC time of this speed 0: acceleration / deceleration time 0 1: acceleration / deceleration time 1 2: acceleration / deceleration time 2 3: acceleration / deceleration time 3 Hundreds and thousands: Reserved	●	0xC1F
FC-32		0000		●	0xC20
FC-33		0000		●	0xC21
FC-34		0000		●	0xC22
FC-35		0000		●	0xC23
FC-36		0000		●	0xC24
FC-37		0000		●	0xC25
FC-38		0000		●	0xC26
FC-39		0000		●	0xC27
FC-40		0000		●	0xC28
FC-41		0000		●	0xC29
FC-42		0000		●	0xC2A
FC-43		0000		●	0xC2B
FC-44		0000		●	0xC2C
FC-45		0000		●	0xC2D

Fd Communication control function parameter group

NO.	Function description	Factory default	Range of settings and definition	Feature	Address
Fd-00	Master-slave machine selection	0	0: Slave machine1: Main machine	○	0xD00
Fd-01	485 communication address	1	1~247	○	0xD01
Fd-02	485 communication baud rate selection	3	0: 1200 bps 1: 2400 bps 2: 4800 bps 3: 9600 bps 4: 19200 bps 5: 38400 bps	○	0xD02
Fd-03	Modbus data format	0	0: (N, 8, 1) 1: (E, 8, 1) 2: (O, 8, 1) 3: (N, 8, 2) 4: (E, 8, 2) 5: (O, 8, 2)	○	0xD03
Fd-04	Communication ratio setting	1.00	0.00~5.00	●	0xD04
Fd-05	Modbus communication answer delay	0ms	0~500ms	●	0xD05
Fd-06	Communication timeout failure time	1.0s	0.1~100.0s	●	0xD06
Fd-07	Modbus communication fault action mode selection	0	0: No detection 1: Alarm and free stop 2: Alarm and continue running 3: Forced stop	●	0xD07
Fd-08	Modbus Responds dispose	0	0: Have response1: No response	●	0xD08

Fd-09	Main machine sending selection	0031	Unit : the first group of transmission frame selection 0: Invalid 1: Main machine run command 2: Main machine given frequency 3: Main machine output frequency 4: Main machine upper limit frequency 5: Main machine given torque 6: Main machine output torque 7, 8: Reserved 9: Main machine given PID A: Main machine feedback PID Tens : the second group transmitting frame selection Hundreds : the third group transmitting frame selection Thousands : the fourth group transmitting frame selection same as above	●	0xD09
Fd-10	RS485 Communication port configuration	0	0: Modbus communication 1: serial port communication	●	0xD0A

Photovoltaic Pump Special Parameters

NO.	Function description	Factory default	Range of settings and definition	Feature	Address
FE-00	Photovoltaic water pump mode	0002	Unit: Mode selection 0: Variable frequency control mode 1: CVT mode for solar 2: MPPT mode Tens: Motor selection 0: Three phase motor 1: Single phase motor Hundreds: Pump clean 0: Invalid 1: valid Thousands: Reserved	○	0xE00
FE-01	CVT Target voltage	81.0%	0.0%~100.0%	●	
FE-02	VOC Voltage	read-only	0.0V~999.9V		0xE02
FE-03	MPPT Voltage upper limit	100.0%	20.0%~200.0%	●	0xE03
FE-04	MPPT Voltage Low Limit	50.0%	20.0%~200.0%	●	0xE04
FE-05	MPPT Search interval	1.0s	0.1s~30.0s	●	0xE05
FE-06	MPPT Adjust gain	100	0~9999	●	0xE06
FE-07	Frequency adjusting gain	10.0%(AM) 40.0%(PM)	0.1%~500.0%	●	0xE07
	Photovoltaic water pump function selection 1	1100H	0: Invalid ; 1: valid Unit : Constant torque frequency limit selection Tens : Reserved Hundreds : Voltage surge updates VOC voltage Thousands : Fast frequency falling function	●	

FE-09	Constant torque frequency limiting factor	100.0%	80.0%~150.0%	●	
FE-10	Voltage surge threshold	5.0%	0.0%~20.0%	●	
FE-11	Fast frequency reduction threshold	5.0%	3.0%~15.0%	●	0xE08
FE-12	Fast frequency reduction gain	2	0~20	●	
FE-13	Frequency adjusted filtering time	0.002	0.001~2.000S	●	0xE09
FE-14	Sleep voltage threshold	250V	0~1000V	●	0xE0B
FE-15	Sleep recovery voltage	350V	0~1000V	●	0xE0C
FE-16	Waiting time of sleep and shutdown	60.0s	0.0~3000.0s	●	0xE0D
FE-17	Detection of low frequency protection frequency	10.00Hz	0.00~300.00Hz	●	0xE0E
FE-18	Detection time of low frequency protection	10.0s	0.0~3000.0s	●	0xE0F
FE-19	Automatic recovery time of low frequency protection	10.0s	0.0~3000.0s	●	0xE10
FE-20	Detection current of dry protection	0.0A	0.0~999.9A	●	0xE11
FE-21	Detection time of drying protection	10.0s	0.0~3000.0s	●	0xE12
FE-22	Automatic recovery time of dry protection	60.0s	0.0~3000.0s	●	0xE13
FE-23	Detection current of over current protection	0.0A	0.0A~999.9A	●	0xE14
FE-24	Detection time of Overcurrent protection	10.0s	0.0s~3000.0s	●	0xE15
FE-25	Automatic recovery time of over current protection	60.0s	0.0s~3000.0s	●	0xE16
FE-26	Minimum power protection value	0.00kw	0.00kw~650.00kw	●	0xE17
FE-27	Detection time of minimum power protection	10.0s	0.0s~3000.0s	●	0xE18
FE-28	Automatic recovery time of minimum power protection	60.0s	0.0s~3000.0s	●	0xE19
FE-29	Alarm recovery mode	0000H	0: Autorecovery1: Manual recovery Unit: Low frequency protection Tens: Dryprotection Hundreds: Overcurrent and overload protection Thousands: Minimum power protection	●	0xE1A
FE-30	Detection time of full water protection	10.0s	0.0s~3000.0s	●	0xE1B
FE-31	Exit time of full water protection	10.0s	0.0s~3000.0s	●	0xE1C

FE-32	Accessibility function	0110H	Unit: 0: The upper limit is limited by the given frequency 1: The upper limit frequency is limited by the rated frequency of the motor Tens: 0: The min Hz is 0; 1: The lower limit frequency is minimum to 1/4 of the motor rated frequency Hundreds: Fault save Thousands: Reserved		
FE-33	DC current correction bias	0.01A	0.00A~99.99A	●	0xE1E
FE-34	DC current correction ratio	100.0%	0.0%~999.9%	●	0xE1F
FE-35	Power curve 0	0.50kw	0.00kw~99.99kw	●	0xE20
FE-36	Power curve 1	1.00kw	0.00kw~99.99kw	●	0xE21
FE-37	Power curve 2	1.50kw	0.00kw~99.99kw	●	0xE22
FE-38	Power curve 3	2.00kw	0.00kw~99.99kw	●	0xE23
FE-39	Power curve 4	2.50kw	0.00kw~99.99kw	●	0xE24
FE-40	Flow curve 0	0.0m ³ /h	0.0m ³ /h~999.9m ³ /h	●	0xE25
FE-41	Flow curve 1	5.0 m ³ /h	0.0 m ³ /h~999.9 m ³ /h	●	0xE26
FE-42	Flow curve 2	10.0m ³ /h	0.0 m ³ /h~999.9m ³ /h	●	0xE27
FE-43	Flow curve 3	15.0m ³ /h	0.0 m ³ /h~999.9m ³ /h	●	0xE28
FE-44	Flow curve 4	20.0m ³ /h	0.0 m ³ /h~999.9m ³ /h	●	0xE29
FE-45	Flow calculation correction bias	0.0m ³	0.0m ³ ~999.9m ³	●	0xE30
FE-46	Flow correction gain	100.0%	0.0%~999.9%	●	0xE31
FE-47	Clearing cycle of daily flow / daily electricity	7.0h	0.0h~24.0h	●	0xE32
FE-48	Initiating frequency of dry run protection	0.00Hz	0.00Hz~150.00Hz	●	0xE33
FE-49	Reserved			●	0xE34
FE-50	Reserved			●	0xE35
FE-51	Reserved			●	0xE36
FE-52	Water tank fulling Level detecting method	0	0:Single point detect 1:Two points detect	●	0xE37
FE-53	Pump cleaning setting frequency	25.00Hz	0.00Hz~300.00Hz	●	0xE38
FE-54	FWD cleaning time	60	0s~3000s	●	0xE39
FE-55	REV cleaning time	60	0s~3000s	●	0xE3A
FE-56	Recycle times of cleaning	10	0~100h	●	0xE3B

4.3 Terminal input function selection

0: No function	1: FWD	2: REV	3: 3-line running(Xi)
4: FWD JOG	5: REV JOG	6: Free stop	7: Emergency stop
8: Fault reset	9: External Fault input	10: Frequency UP	11: Frequency DW
12: UP/DW clear	13: Channel A to Channel B	14: Frequency channel switched to A	15: Frequency channel switched to B
16: Multi-speed terminal 1	17: Multi-speed terminal2	18: Multi-speed terminal3	19: Multi-speed terminal4
20: PID control cancel	21: PID control pause	22: PID trait switch	23: PID gain switch
24: PID given switch 1	25: PID given switch2	26: PID given switch3	27: PID feedback switch1
28: PID feedback switch2	29: PID feedback switch3	30: PLC pause	31: PLC restart
32: ACC/DEC time selection terminal 1	33: ACC/DEC time selection terminal 2	34: ACC/DEC pause	35: Swing frequency input
36: Swing frequency pause	37: Swing frequency reset	38: Speed torque control switch	39: Run pause
40: Timer trigger terminal	41: Timer clear terminal	42: Counter input terminal	43: Counter clear terminal
44: DC braking command	45: Pre-excitation command terminal	46: Command channel switch to keyboard	47: Command channel switch to terminal
48: Command channel switch to RS485	49: Command channel switch to expansion card	50: Operation banned	51: FWD banned
52: REV banned	53: Water-full detect alarm 1	54: Water-full detect alarm 2	55: Hybrid mode
56: Dry running input	57: MPPT tracking stop	Reserved	

4.4 Terminal output function selection

0: No output	1: Inverter running	2: REV running	3: FWD running
4: Fault warning 1,enable output including fault reset auto period	5: Fault trip alarm 2(no alarm when fault self-recovery)	6: External fault stop	7: External fault stop Under voltage
8: Ready for running	9: Output frequency level detection 1(FDT1)		10: Output frequency level detection 2(FDT2)
12: 0 speed running	13: Reach upper limit frequency	14: Reach lower frequency limit	15: Program run cycle completed
16: Program running segment completed	17: PID feedback exceeds upper limit	18: PID feedback under lower limit	19: PID feedback sensor wires break
20: Timer time arrived	21: Counter reaching max value	22: Counter reach set value	23: Braking
24: PG feedback wire break	25: Emergency stopping	26: Load pre-alarm output 1	27: Load pre-alarm output 2
28: RS485 given	Reserved		

4.5 Monitoring code

Access 'C' parameter group by pressing 'PRG' for more than 2s; check the current state of inverter.

Function code number	Function name	Unit and definition	Address
C-00	Given frequency	0.01Hz	2100H
C-01	Output frequency	0.01Hz	2101H
C-02	Output current	0.1A	2102H
C-03	DC voltage of PV arrays	0.1V	2103H
C-04	Output voltage	0.1V	2104H
C-05	Motor(pump)speed	1RPM	2105H
C-06	Current of PV arrays	0.1A	2106H
C-07	Power of PV arrays	0.1KW	2107H
C-08	Given torque	0.1%	2108H
C-09	Output torque	0.1%	2109H
C-10	PID given value	0.1%	210AH
C-11	PID feedback value	0.1%	210BH
C-12	Module temperature 1	0.1 °C	210CH
C-13	Module temperature 2	0.1 °C	210DH
C-14	Input terminal X on state	See input terminal diagram	210EH
C-15	Output terminal Y on state	See output terminal diagram	210FH
C-16	Input value of analog signal AI1	0.001V	2110H
C-17	Input value of analog signal AI2	0.001V/0.001mA	2111H
C-18	Analog output AO	0.01V/0.01mA/0.01kHz	2112H
C-19	VOC voltage	0.1 V	2113H
C-20	Flow rate of pump	0.1 m ³ /h	2114H
C-21	Day flow	0.1 m ³	2115H
C-22	Flow accumulation (low-order digit)	0.1m ³	2116H
C-23	Flow accumulation (high-order digit)	0.1km ³	2117H
C-24	Day generated power	0.01kwh	2118H
C-25	Generated accumulation	0.01kwh	2119H
C-26	Generated accumulation	0.1Mwh	211AH
C-27	Output power	0.01kw	211BH
C-28	Software version		211CH
C-29	Inverter Working status	0: Stop 1: Running 2: Sleep 3: Low speed protection 4: Dry run protection 5: Over current protection 6: Minimum power protection	211DH

4.6 Fault code table

Communication code	Fault display	Fault name	Troubleshooting	Solution
1	E.SC	System abnormal	<ul style="list-style-type: none"> ● The acceleration time is set too short; ● The output of the inverter is short-circuited between phases or to ground; ● The module is damaged; ● Electromagnetic interference. 	<ul style="list-style-type: none"> ● Prolong the acceleration time appropriately; ● Check peripheral equipment and restart after troubleshooting; ● Seek technical support from manufacturers; ● Check the wiring, grounding, and shielding.
4	E.oC1	ACC over current	<ul style="list-style-type: none"> ● The acceleration time is set too short; ● Start the rotating motor; ● The capacity of the inverter is too small. 	<ul style="list-style-type: none"> ● Prolong the acceleration time appropriately; ● The motor stops or restarts after speed tracking; ● Use inverters with matching capacity levels
5	E.oC2	DEC over current	<ul style="list-style-type: none"> ● The deceleration time is set too short; ● Large potential energy load or load inertia; ● The capacity of the inverter is too small. 	<ul style="list-style-type: none"> ● Prolong the deceleration time appropriately; ● External braking resistor or braking unit; ● Select the inverter with matching capacity level.
6	E.oC3	Overcurrent at constant speed	<ul style="list-style-type: none"> ● Sudden load change; ● The grid voltage is low. 	<ul style="list-style-type: none"> ● Check the change of load and eliminate it; ● Check the input power and remove the fault.
7	E.oU1	ACC over voltage	<ul style="list-style-type: none"> ● Power supply voltage fluctuation exceeds the limit; ● Start the rotating motor. 	<ul style="list-style-type: none"> ● Detect the grid voltage and remove the fault; ● The motor stops or restarts after speed tracking;
8	E.oU2	DEC over voltage	<ul style="list-style-type: none"> ● The DEC time is set too short; ● Load potential energy or inertia is too large; ● The power supply voltage has exceeded the limit. 	<ul style="list-style-type: none"> ● Prolong the DEC time appropriately; ● Increase the capacity of the inverter or add a braking unit; ● Check the input power and remove the fault.
9	E.oU3	Overvoltage at constant speed	<ul style="list-style-type: none"> ● The power supply voltage has exceeded the limit. 	<ul style="list-style-type: none"> ● Check the input power and remove the fault.
10	E.LU2	Under voltage when running	<ul style="list-style-type: none"> ● The power supply voltage is too low; ● There is a large inrush current in the power grid; ● The internal DC main contactor is not closed. 	<ul style="list-style-type: none"> ● Check the input power and remove the fault; ● Improve the power supply system; ● Seek technical support from the manufacturer.

11	E.oL1	Motor overload	<ul style="list-style-type: none"> ● The grid voltage is low; ● Motor overload protection coefficient is not set properly; ● The motor is stalled or the load is too heavy; ● Low speed running. 	<ul style="list-style-type: none"> ● Check the input power; ● Use inverters with matching capacity levels; ● For long-term low-speed operation, select a dedicated motor. ● Speed regulation overload coefficient
12	E.oL2	Inverter overload	<ul style="list-style-type: none"> ● The load is too heavy ● The acceleration time is set too short; ● Start the rotating motor; 	<ul style="list-style-type: none"> ● Use inverters with matching capacity levels; ● Prolong the acceleration time appropriately; ● The motor stops or restarts after speed tracking;
13	E.iLF	Input phase loss	<ul style="list-style-type: none"> ● The input power is abnormal; ● The internal circuit is abnormal; 	<ul style="list-style-type: none"> ● Check the input power; ● Seek technical support from the manufacturer.
14	E.oLF	Output phase loss	<ul style="list-style-type: none"> ● The three-phase output of the inverter is lacking. 	<ul style="list-style-type: none"> ● Check the output voltage, current and motor wiring;
15	E.oH2	Rectifier overheat	<ul style="list-style-type: none"> ● The ambient temperature is too high; ● The air duct is blocked or the fan is abnormal; ● The temperature detection circuit is faulty. 	<ul style="list-style-type: none"> ● Make the operating environment of the inverter meet the specifications; ● Drain the air duct or replace the fan of the same model; ● Seek technical support from the manufacturer.
16	E.oH1	Inverter overheat	<ul style="list-style-type: none"> ● The ambient temperature is too high; ● The air duct is blocked or the fan is abnormal; ● The temperature detection circuit is faulty. 	<ul style="list-style-type: none"> ● Make the operating environment of the inverter meet the specifications; ● Drain the air duct or replace the fan of the same model; ● Seek technical support from the manufacturer.
17	E.EF	External fault	<ul style="list-style-type: none"> ● External equipment failure protection action. 	<ul style="list-style-type: none"> ● Check external equipment.
18	E.SE1	RS485 communication fault	<ul style="list-style-type: none"> ● The baud rate is set incorrectly; ● Communication connection is broken; ● The communication format does not match the host computer. 	<ul style="list-style-type: none"> ● Set the matching baud rate; ● Check communication connections; ● Set the matching communication format.
19	E.HAL	Current detection fault	<ul style="list-style-type: none"> ● Detection circuit failure; ● Motor phase imbalance. 	<ul style="list-style-type: none"> ● Seek technical support; ● Check the motor and wiring.

20	E.AT1	Motor static self-learning fault	<ul style="list-style-type: none"> ● Motor detection timeout; ● Start static detection while the motor is rotating; ● The difference between the capacity of the motor and the inverter is too large; ● The motor parameters are set incorrectly. 	<ul style="list-style-type: none"> ● Check the motor wiring; ● Test after the motor stops steady; ● Replace the inverter model; ● Reset according to the motor nameplate.
21	E.EEP	Storage fault	<ul style="list-style-type: none"> ● Electromagnetic interference during storage; ● EEPROM is damaged. 	<ul style="list-style-type: none"> ● Re-enter and save; ● Seek technical support from the manufacturer.
25	E.AT2	Motor dynamic self-learning fault	<ul style="list-style-type: none"> ● Start detection while the motor is rotating; ● Motor with load detection; ● Motor detection timeout; ● The difference between the capacity of the motor and the inverter is too large; ● The motor parameters are set incorrectly. 	<ul style="list-style-type: none"> ● Test after the motor stops steady; ● Disconnect the motor load and re-test; ● Check the motor wiring; ● Replace the inverter model; ● Reset according to the motor nameplate.
27	E. PG	PG card connection fault	<ul style="list-style-type: none"> ● PG card connect the inverter fault 	<ul style="list-style-type: none"> ● check the PG wiring
28	E.OU4	Over voltage at stop	<ul style="list-style-type: none"> ● The power supply voltage has exceeded the limit. 	<ul style="list-style-type: none"> ● Check the input power and remove the fault. ● Seek technical support from the manufacturer.
29	E.PID	PID feedback fault	<ul style="list-style-type: none"> ● PID feedback disconnect alarm upper limit ● PID feedback disconnection alarm lower limit ● The feedback sensor is faulty or badly wired 	<ul style="list-style-type: none"> ● Check the sensor status ● Correct wiring ● Confirm the setting values of Fb-27 and Fb-28
30	E.Rsv	Reserved	---	---
31	E.IAE	Learning fault of Initial position angle	<ul style="list-style-type: none"> ● The parameters set fault; ● Detection circuit fault; 	<ul style="list-style-type: none"> ● Replacement of inverter type; ● Reset according to motor nameplate. ● Seek technical support from the manufacturer.
32	E.DEV	Speed deviation excess	<ul style="list-style-type: none"> ● The Speed over the max frequency. ● Detection circuit fault; 	<ul style="list-style-type: none"> ● Change the Max frequency and Upper frequency. ● Seek technical support from the manufacturer.
33	E.SPD	Stall protection	<ul style="list-style-type: none"> ● Inverter over voltage; ● Detection circuit fault; 	<ul style="list-style-type: none"> ● Change the over voltage set. ● Seek technical support from the manufacturer.
34	E.LD1	Load protection 1	<ul style="list-style-type: none"> ● The motor is stalled over the set value. ● Detection circuit fault; 	<ul style="list-style-type: none"> ● Change the set value. ● Seek technical support from the manufacturer.

35	E.LD2	Load protection 2	<ul style="list-style-type: none"> ● The motor is stalled over the set value. ● Detection circuit failure; 	<ul style="list-style-type: none"> ● Change the set value. ● Seek technical support from the manufacturer.
36	E.CPU	CPU over time	<ul style="list-style-type: none"> ● CPU calc over load. 	<ul style="list-style-type: none"> ● Seek technical support from the manufacturer.
37	E.LOC	CPU verification fault	<ul style="list-style-type: none"> ● CPU is Locked. 	<ul style="list-style-type: none"> ● Seek technical support from the manufacturer.
38	E.PST1	Synchronous motor out-of step	<ul style="list-style-type: none"> ● The motor is stalled or the load is too heavy; ● Detection circuit failure; 	<ul style="list-style-type: none"> ● Change the Power of inverter; ● Seek technical support from the manufacturer.

Alarm code table

Communication code	Alarm display	Alarm name	Communication code	Alarm display	Alarm name
64	A.LU1	Main Relay fault	74	A.CE	RS485 Communication alarm
66	A.PID	PID feedback wires brake alarm	75	A.SLP	Sleep mode alarm
67	A.LD1	Load protection alarm 1	76	A.LFr	Low frequency alarm
68	A.LD2	Load protection alarm 1	77	A.LLd	Dry running alarm
69	A.EEP	Storage alarm	78	A.OLd	Over current alarm
70	A.DEF	Speed deviation excess	79	A.LPr	Minimum power alarm
71	A.SPD	Stall protection alarm	80	A.FuL	Water full alarm

Chapter 5 Regular Inspection and Maintenance

5.1 Inspection

Frequency inverter is composed by semi-conductive components, passive electronic component and motive component. All of these components have useful life. Even under normal working environment, some of the components cannot work after the life time. To avoid malfunction, daily checking, periodic overhaul, component changing and other maintenance should be carried out to prevent.

● Daily checking: To avoid machine damage and to prolong life time, please check the following items every day.

Check item	Check content	Standard of criterion
Input and output voltage	Check whether the power supply voltage meets the requirements and whether there is phase failure	Refer to the requirements of the name plate
Operating environment	Confirm whether the installation environment meets the requirements	Identify the source and deal with it properly
Cooling system	Working condition of cooling fan of frequency converter	There is no dirt and debris blocking the air duct
Motor	Check if there is abnormal vibration or noise	Whether there is abnormal heating, abnormal noise and vibration
Load condition	Whether the output current of frequency converter is higher than the rated value of motor or frequency converter and lasts for a certain time	Confirm whether there is overload and whether the inverter selection is correct

● Periodic inspection: According to the operating environment and working conditions, the frequency converter shall be inspected regularly every 3-6 months.

Check item	Check content	Strategy adopted
Motor	<ul style="list-style-type: none"> ● Insulation resistance inspection; ● Check if there is abnormal vibration or noise. 	<ul style="list-style-type: none"> ● Tighten machine and electric connection and lubricate the machine components.
Electric connection	<ul style="list-style-type: none"> ● Whether there is any discoloration of the wires and connection parts, whether the insulation layer is damaged, cracked, discolored, and aged; ● Whether the connection terminals are worn, damaged, or loose; 	<ul style="list-style-type: none"> ● Replace damaged wires; ● Tighten loose terminals and replace damaged terminals; ● Measure the ground resistance and tighten the corresponding ground terminal.
Mechanical connection	<ul style="list-style-type: none"> ● Whether there is abnormal vibration and noise, and whether there is loosening. 	<ul style="list-style-type: none"> ● Tighten, lubricate, and replace defective parts.
semi-conductive component	<ul style="list-style-type: none"> ● Whether it is stained with garbage and dust; ● Whether there is a noticeable change in appearance. 	<ul style="list-style-type: none"> ● Clean operating environment; ● Replace damaged parts.
Electrolytic capacitor	<ul style="list-style-type: none"> ● Check for leaks, discoloration, cracks, and exposed, swollen, cracked, or leaking safety valves. 	<ul style="list-style-type: none"> ● Replace damaged parts.

Check item	Check content	Strategy adopted
PCB	<ul style="list-style-type: none"> ● Check if there is any odor, discoloration, severe rust, and whether the connector is correct and reliable. 	<ul style="list-style-type: none"> ● Fastening connection ● Clean the printed circuit board; ● Replace damaged printed circuit boards;
Cooling system	<ul style="list-style-type: none"> ● Whether the cooling fan is damaged or blocked; ● Whether the heat sink is stained with garbage, dust, or dirt; ● Whether the air intake or exhaust is blocked or contaminated with foreign objects. 	<ul style="list-style-type: none"> ● Clean operating environment; ● Replace damaged parts.
Keyboard	<ul style="list-style-type: none"> ● Whether it is damaged. Check whether display is complete. 	<ul style="list-style-type: none"> ● Change damaged component

Attention:

Do not perform related operations with the power on, otherwise there is a danger of death due to electric shock. When carrying out related work, please cut off the power and confirm that the DC voltage of the main circuit has dropped to a safe level. Wait 5 minutes before carrying out related work.

- Component replacement: Different kinds of parts have different service life. The service life of parts is closely related to the service environment and maintenance condition. Cooling fan and electrolytic capacitor are vulnerable parts. Carry out daily inspection according to the table below. If there is any abnormality, please replace it in time.

Part name	life cycle	Cause of damage
Fan	2~3 years	Bearing wear and blade aging
Electrolytic capacitor	4~5 years	The environment temperature is high and the electrolyte volatilizes

The replacement of other components requires very strict maintenance technology and product familiarity, and after replacement, it must be strictly tested before it can be used. Therefore, it is not recommended that users replace other internal components by themselves. If it really needs to be replaced, please contact the agent where you purchased the product or our sales department.

5.2 Product storage

After purchasing the frequency converter, the temporary storage and long-term storage must pay attention to:

- When storing, try to put them into the packing box of our company according to the original package;
- The long-term storage will lead to the deterioration of the electrolytic capacitor. It must be ensured that the electrolytic capacitor is powered on once within 2 years for at least 5 hours, and the input voltage must be slowly raised to the rated value with a voltage regulator.

Chapter 6 Operation Guidance

6.1 Asynchronous Motor Pump Drive Operation Guidance

1) Wiring:

Confirmed the solar pump inverter selecting if suitable for pump. The rated current of inverter must be bigger than rated current of pumps.

Selecting correct solar arrays for inverter. The Vmp should be 310VDC for 220VAC pump, 540Vmp for 380VAC pump.

And total power of solar arrays must be larger 1.3 times of AC pumps.

Correct connect P+ terminals to positive pole of solar panel, P- (N) to negative pole of solar panels. Otherwise it will cause inverter damage. (It also can connect DC solar power to R and T and no need distinguish poles of panels)

Connect motor wire and ground wire to corresponding U, V, W, E terminals.

2).Parameters setting and trial run:

Set F0-01 to 0, F0-02 for 0, and F0-09, F0-11, F0-14, F0-15 parameters setting according to application site.

Set pumps parameters according to nameplate of pump in F5-00, F5-01, F5-02, F5-03, F5-04, F5-05 parameters.

Set solar pump MPPT mode FE-00 for 0002, PE05 , PE06 and PE07 parameters use to change the MPPT gain.

Press RUN button for trail running, and confirm the motor running direction.

3) Common problems and solutions

a, Q: Well-lit conditions, the pump is running, but the water is very small.

A: Check if the pump motor direction is reversed.

b, Q: Well-lit conditions, the drive is in standby mode 0.00Hz.

A : Check C-29, observe what protection status is the drive in currently, check whether the parameters set is reasonable.

c, Q: DC current is incorrectly displayed.

A: Adjust FE-33 ,FE-34 for calibration.

d, Q: Well-lit conditions,frequency severe beating during operation.

A: PE05, PE06 and FE-07 parameters can use to adjust output frequency stability.

6.2.Synchronous Motor Pump Drive Operation Guidance

1) Wiring:

Confirmed the solar pump inverter selecting if suitable for pump. The rated current of inverter must be bigger than rated current of pumps.

Selecting correct solar arrays for inverter. The Vmp should be 310VDC for 220VAC pump, 540Vmp for 380VAC pump.

And total power of solar arrays must be larger 1.3 times of AC pumps.

Correct connect P+ terminals to positive pole of solar panel, P- (N) to negative pole of solar panels. Otherwise it will cause inverter damage. (It also can connect DC solar power to R and T and no need distinguish poles of panels)

Connect motor wire and ground wire to corresponding U, V, W, E terminals.

2) Parameters setting and trial run:

a. Set F0-01 to 3, F0-02 for 0, and F0-09, F0-11, F0-14, F0-15 can be set according to demand.

b. Set motor (pump) parameters according to nameplate of pump. Then Set F5-20 for 1, the keypad will show T-00, press RUN to start motor auto tuning. This process takes about three minutes;

Note:

1. If you can disconnect the motor and load, self-learning would be better;

2. The self-learning need to be done with enough sunshine and when the solar panels can provide enough energy.

c. Set solar pump MPPT mode FE-00 for 2 (MPP) mode

d. Press RUN button for trial running, and confirm the motor running direction.

3) Common problems and solutions

a, Q: Well-lit conditions, the pump is running, but the water is very small.

A: Check if the pump motor direction is reversed.

b, Q: Well-lit conditions, the drive is in standby mode 0.00Hz.

A: Check C-29, observe what protection status is the drive in currently, check whether the parameters set is reasonable.

c, Q: DC current is incorrectly displayed.

A: Adjust FE-33, FE-34 for calibration.

d, Q: Well-lit conditions, frequency severe beating during operation.

A: Reasonably adjust PE05, PE06 FE-07 value, the adjustment is recommended to be in the vicinity of the default, too big or too small will cause frequency oscillation.

6.3. Introduction of photovoltaic water pump function

A. Sleep Function

During the photovoltaic pump operation, the inverter will go into sleep state when the DC voltage provided by solar panels is lower than FE-14 (sleep voltage threshold) due to objective factors, while the keyboard warning "A.SLP"; when DC voltage provided by solar panels rises back to FE-15 (sleep recovery voltage) point, start timing and after FE-16 (sleep shutdown waiting time), the drive starts running.

B. Low-frequency Protection Function

During the operation of the photovoltaic pump, for some reason, the output frequency is lower than FE-17 (low frequency detection frequency), and after FE-18 (under frequency detection time) time, enters into the standby protection state, while the keyboard warning "A.LFr"; after entering into the standby protection state and after FE-19 (frequency protection automatic recovery) time, automatically resume to running state.

C. Dry Run Protection

During the operation of the photovoltaic pump, for some reason, the output current is less than FE-20 (dry protection current detection), and after FE-21 (dry protection detection time) time, enters into standby protection state, while the keyboard warning "A.LLd"; after entering into the standby protection state and after FE-22 (dry protection automatic recovery) time, automatically resume to running state.

D.Over-current Protection

During the operation of the photovoltaic pump, for some reason, the output current is greater than FE-23(over current point setting), and after FE-24 (over current protection detect time) time, enters into standby protection state, while the keyboard warning " A.oLd "; after entering into the standby protection state and after FE-25 (over current protection auto recovery)time, automatically resume to running state.

E.Minimum Power Protection

During the operation of the photovoltaic pump, for some reason, the output power is less than FE-26(minimum power protection value), and after FE-27 (minimum power protection detection time) time, enters into standby protection state, while the keyboard warning "A.LPr"; after entering into the standby protection state and after FE-28 (minimum power automatic recovery)time, automatically resume to running state.

F.Full Water Protection

Detect the water full alarm and low water level through two X terminals, realizing automatic water level control. Where in FE-30 is the water overflow protection detection time and FE-31 is full water protection exit time, X3 terminal is photovoltaic water full detection alarm signal input, X4 terminal is photovoltaic water full detection alarm reset input,the warning signal is shown as "A.Ful".

G.Alarm Recovery Mode: 0: automatic recovery; 1: manual recovery

This option is for low frequency protection, dry protection, over-current protection, minimum power function; you can select the alarm restoration by FE-29. When you select 0 for automatic recovery, during fault warning displaying, you can also press the "RESET" button to stop operation; during fault warning displaying, you can press the "RESET" button to manually clear, you can also press "RESET" button to achieve stop operation.

H.PQ Curve Function

This model provides a self-defined PQ curve for users to set up five groups of PQ corresponding points according to the pump cases, to achieve real-time traffic speed, daily flow, cumulative flow, generating capacity, cumulative electricity consumption; of which by default, daily flow and generating capacity are calculated based on 7h in a day.

I.Status Check

When the photovoltaic pump is running, you can check C-29 to confirm the current operating status.

Appendix1:Modbus Communication Protocol

● Communication Frame Structure

Communication data format is as follows:The byte composition: Including initiation bit, 8 data bit, check bit and stop bit.

Initiation Bit	Bit1	Bit2	Bit3	Bit4	Bit5	Bit6	Bit7	Bit8	Check bit	Stop bit
----------------	------	------	------	------	------	------	------	------	-----------	----------

One frame message must be transmitted as a continued data flow, and if there is a interval over 1.5 byte before ending, the receiving equipment will clear the half-baked information. And the next byte will be considered as the address field of a new frame. Similarly, if the interval between a new frame start-up and the former frame is smaller than 3.5 byte time, the receiving equipment will consider that it is the continuation of former one frame. Since the jumbled frame, the final CRC checking value is incorrect, which would lead to the communication mistake.

● Communication command and examples

Read command: 03H,Read N words.Up to 20 words read in succession.

Example: The slave machine address is 01H,read 3 successive words of start address 2100H(C-00), The structure of the frame is described as follows:

RTU Main machine command		RTU slave machine return message(normal)		RTU slave machine return message(abnormal)	
START	3.5 bytes	START	3.5 bytes	START	3.5 bytes
Slave address	01H	Slave address	01H	Slave address	01H
Command code	03H	Command code	03H	Command code	83H
start address high bits	21H	Return data numbers	06H	Fault code	04H
start address low bits	00H	high bit of 2100H	13H	CRC CHK low bits	40H
Data numbers high bits	00H	low bit of 2100H	88H	CRC CHK high bits	F3H
Data numbers low bits	03H	high bit of 2101H	00H	END	3.5 bytes
CRC CHK low bits	0FH	low bit of 2101H	00H		
CRC CHK high bits	F7H	high bit of 2102H	00H		
END	3.5 bytes	low bit of 2102H	00H		
		CRC CHK low bits	90H		
		CRC CHK high bits	A6H		
		END	3.5 bytes		

Write command: 06H, Write a word data to the specified data address, this command can change the parameter of inverter.

Example: Write 1388Hto the address 3000H of the slave controller. The structure of the frame is described as follows:

RTU Main machine command		RTU slave machine return message(normal)		RTU slave machine return message(abnormal)	
START	3.5 bytes	START	3.5 bytes	START	3.5 bytes
Slave address	01H	Slave address	01H	Slave address	01H
Command code	06H	Command code	06H	Command code	86H
start address high bits	30H	Data address high bits	30H	Fault code	01H
start address low bits	00H	Data address low bits	00H	CRC CHK low bits	83H
Data high bits	13H	Data high bits	13H	CRC CHK high bits	A0H
Data low bits	88H	Data low bits	88H	END	3.5 bytes
CRC CHK low bits	8BH	CRC CHK low bits	8BH		

CRC CHK high bits	9CH	CRC CHK high bits	9CH		
END	3.5 bytes	END	3.5 bytes		

● **Communication Control Parameter Group Address Specification:**

Function Specification	Address	Data Meaning Specification		R/W
Communication Given Frequency	0x3000 or 0x2000	0~60,000 is corresponding to 0.00Hz~600.00Hz		W/R
Communication Command Setting	0x3001 or 0x2001	0000H: No order 0001H: FWD running 0002H: REV running 0003H: FWD jog 0004H: REV jog	0005H: DEC stop 0006H: free stop 0007H: Fault reset 0008H: Running banned command 0009H: Running allowed command	W/R
State of Inverter	0x3002 or 0x2002	Bit0	0: stop 1: running	R
		Bit1	0: non-acc state 1: ACC	
		Bit2	0: non-dec state 1: DEC	
		Bit3	0: Forward 1: REV	
		Bit4	0: normal 1: fault	
		Bit8	0: normal 1: Sleep	
		Bit9	0: normal 1: Low frequency	
		Bit10	0: normal 1: Dry run	
		Bit11	0: normal 1: Over current	
Bit12	0: normal 1: Low power			
Frequency Inverter Fault Code	0x3003 or 0x2003	current inverter fault code(refer to fault code table)		R
Communication Given Upper Frequency	0x3004 or 0x2004	0~32000 is corresponding to 0.00Hz~320.00Hz		W/R
Communication Torque Setting	0x3005 or 0x2005	0~1000 is corresponding to 0.0~100.0%		W/R
The FWD Max Frequency limit in Torque Control	0x3006 or 0x2006	0~1000 is corresponding to 0.0~100.0%		W/R
The REV Max Frequency limit in Torque Control	0x3007 or 0x2007	0~1000 is corresponding to 0.0~100.0%		W/R
Communication Given PID Setting	0x3008 or 0x2008	0~1000 is corresponding to 0.0~100.0%		W/R
Communication Given PID Feedback	0x3009 or 0x2009	0~1000 is corresponding to 0.0~100.0%		W/R
AO output	0x3021 or 0x2021	0-10000 corresponds output 0-10V, 0-20mA		R

Note: The other function code addresses refer to “Communication Address” of function code table. While using writing command (06 H), if the highest digit of parameter function code address domain is 0, it only write in the RAM of inverter, and on storage when power off; if the high half digit of parameter function code address is 1, it write in EEPROM, which means power off storage. For instance, F0 parameter group: 0X00XX (RAM); 0X10XX (EEPROM)

● **List of fault code meanings for abnormal response information from salve machine:**

Fault Code	Meanings	Fault Code	Meanings
1	Order code fault	7	Reserved
3	CRC checking fault	8	Inverter busy(EEPROM is storing)
4	Illegal address	9	Value over limit

5	Illegal data	10	Reserved parameters can't be modify
6	Unable to modify when running	11	Number of Bytes wrong when reading

Appendix 2:Terminal connection mode

0: Two wire control 1

Operation and direction are integrated. This mode is the most commonly used two-wire mode. The factory default is X1 (forward running) and X2 (reverse running) terminal commands to determine the forward and reverse operation of the motor. As shown in the figure below:

K1	K2	Run command
0	0	Stop
1	0	Forward
0	1	Reverse
1	1	Stop

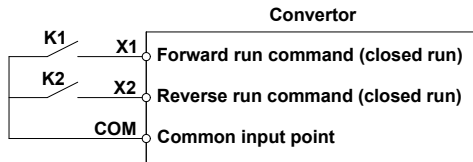

Schematic diagram of two-wire control 1

1: Two wire control 2

Operation is separated from direction. When using this mode, the forward running Terminal X1 (forward running) defined is the operation enabling terminal. The definition of the direction is determined by the state of the reverse operation terminal X2 (reverse operation). As shown in the figure below:

K1	K2	Run command
0	0	Stop
1	0	Forward
1	1	Reverse
0	1	Stop

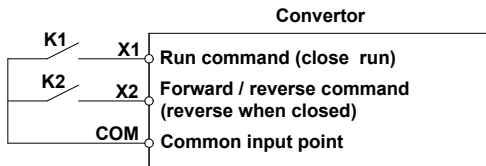

Schematic diagram of two-wire control 2

2: Three wire control1

In this mode, the three wire operation control terminal (X1) is the stop operation terminal, the operation command is generated by the forward rotation operation terminal X1 (forward rotation operation), and the direction is controlled by the reverse operation terminal X2 (reverse operation). The three wire operation control terminal (X1) is the effectiveinput.

K1	Direction control
0	Forward
1	Reverse

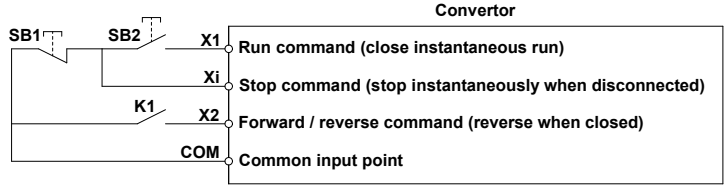

Schematic diagram of three-wire control 1

3: Three wire control2

In this mode, in three wire system, the operation control terminal (Xi) is the stop operation terminal, and the operation command is generated by the forward rotation operation terminal X1 (forward rotation operation) or the reverse operation terminal X2 (reverse operation), and both control the operation direction at the same time.

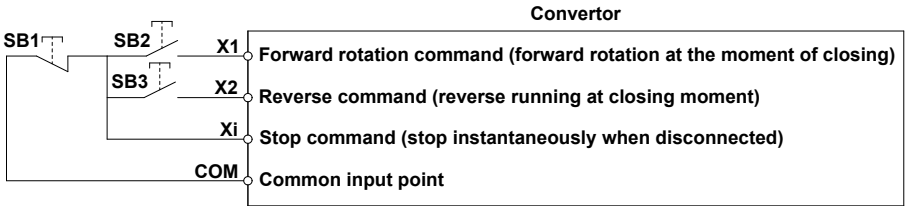

Schematic diagram of three-wire control 2

Tips:

SB1: stop button; SB2: forward rotation operation button; SB3: reverse operation button; Xi is the multi-function input terminal set as "3" [three wire operation control (Xi)].

Appendix 3: Terminal connection mode

Input voltage, power solar arrays selection				
Pumps model	Inverter models	Vmp	Voc	Total Power of solar arrays
110VAC pumps	D1/S1	110*1.41=155VDC	190VDC	\cong (1.3 to 2.0) rated power of pumps It is also depend on the quality of solar panels. The more power input, the better performance.
220VAC pumps	D2/S2	220*1.41=310VDC	372VDC	
380VAC pumps	D3/T3 (Max 800VDC)	380*1.41=540VDC	648VDC	
480VAC pumps	D5/T5 (Max 900VDC)	480*1.41=677VDC	812VDC	

Although solar pump inverter built in high efficiency MPPT tracking arithmetic, up to 99.6% MPPT efficiency, but also need to consider many factors of solar radiation. It is no certain rules to determine exactly how many piece solar panels exactly input for system. If the output frequency can't get to 50Hz/60Hz, please consider to connect more solar panels.

Solar arrays selection tables as AC pumps.

Connecting solar panels in series to get enough voltage input, and then calculating how much strings for getting enough power.

Take a solar panels Voc38VDC, Vmp 31VDC, 265W for exempling.

Please check if enough DC voltage input for system, Voc and Vmp. 2S (310vmp), 380V (540vmp).

If the output frequency is not high, lower than 50/60Hz even in good sunlight radiation, please check if enough solar panels have been connected. The total power should be at least bigger 1.3 times than of rated power of pumps.

Solar panel spec.:265w, 38Voc (Open circuit voltage), 31Vmp (Voltage at Pmax)				
Inverter models	Power of pump	Connection in series (PCS) (Vmp)	Connect in parallel (Strings) Power	Total (PCS)
S1/D1 (110VAC)	0.75kw to 1.0kw	4 or 5 PCS	1* strings	5*1=5
S2/D2 (220VAC)	0.75kw to 1.5kw	10PCS	1* strings	10*1=10
S2/D2(220VAC), Max 450vdc	2.2kw	11PCS	1* strings	11*1=11
T3/D3(380VAC)	0.75kw to 2.2kw	18PCS	1* strings	18*1=18
T3/D3(380VAC)	3.7kw	20PCS	1* strings	20*1=20
T3/D3(380VAC)	5.5kw	18PCS	2* strings	18*2=36
T3/D3(380VAC)	7.5kw	20pcs	2* strings	20*2=40
T3/D3(380VAC)	11kw	18pcs	3* strings	18*3=54
T3/D3(380VAC)	15kw	20pcs	4* strings	20*4=80